

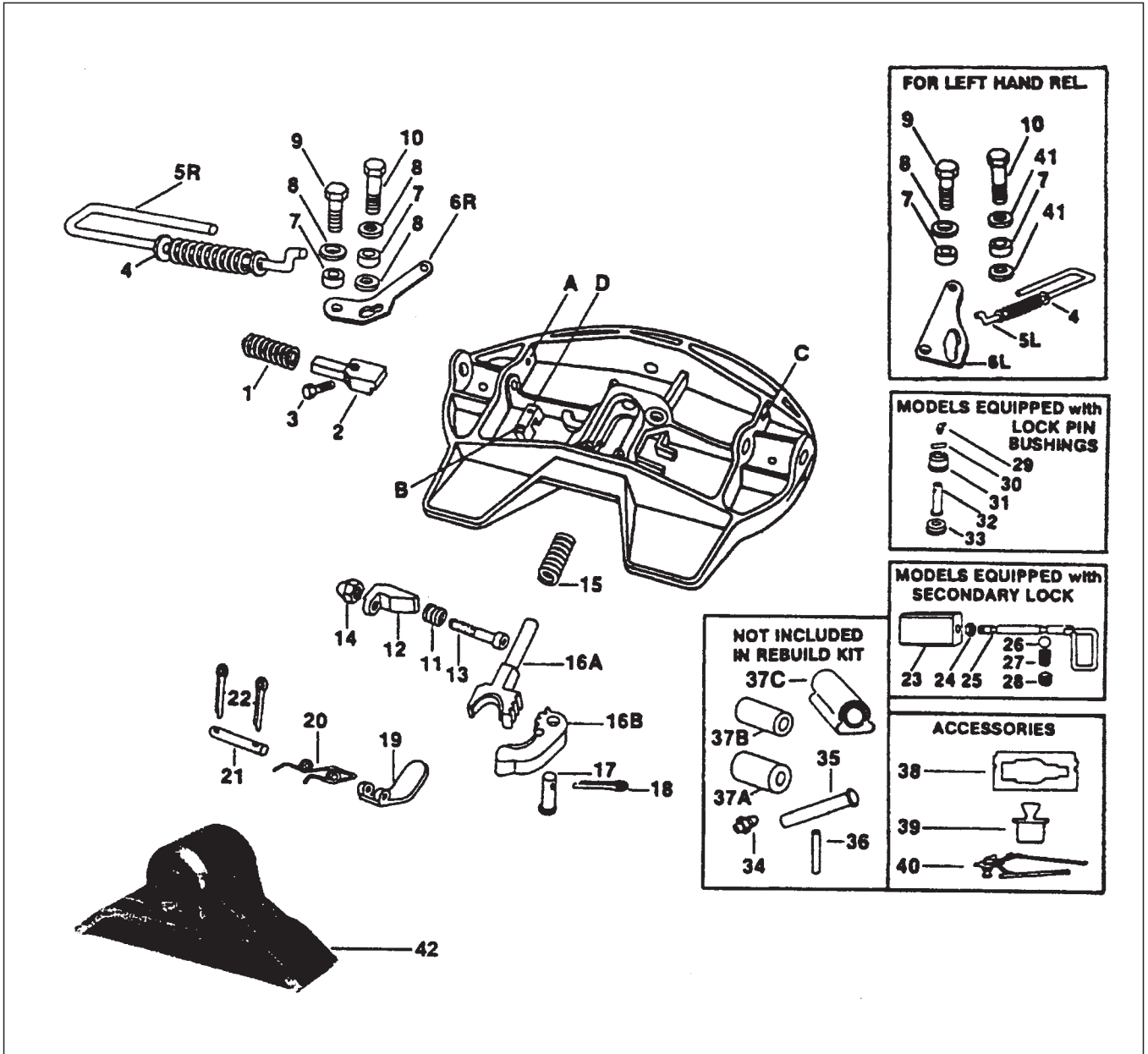

# FW2000 SERIES TOP PLATE





## FW2000 SERIES TOP PLATE

ITEM	PART No.	No. REQUIRED	PART NAME
1	XB1007	1	Comp spring 1 5/8" O.D. x 5"
2	XA1119	1	Plunger
3	XB15	1	Set screw
4	XBT49	1	Plain washer 1/2"
5L	RK1117/1LK	1	Left hand release handle (Item No 4 must be installed on handle for complete assy.)
5R	RK1117/1	1	Right hand release handle (Item No 4 must be installed on handle for complete assy)
6L	XA1118/2/L	1	Left hand cam plate
6R	XA1118/1	1	Right hand cam plate
7	XA1029	2	Roller
8	XB1030	3	Washer (for right hand)
		1	Washer (for left hand)
9	XB2083	1	Hex hd screw 1/2" - 20 x 1 3/4" with locking patch. Packaged as RK2083 K with 1 P/N8
10	XB1031	1	1/2" -20 x 2" Hex. hd cap screw
11	XB403	1	Spring
12	XD3123/1	1	Lock adjusting wedge
13	XB2001	1	5/8" - 11 x 3 3/4" Soc hd. screw
14	XBHNNH58C	1	5/8" - 11 lock nut
15	XB1006	1	Comp spring 1 1/4" O.D. x 5"
16	XA1102	1	Lock set
17	XA1016	1	Hinged lock pin
18	XB5	1	Cotter pin 1/4" x 2"
19	XA1621	1	Lock guard
20	XB1044	1	Torsion spring
21	XA1055	1	Pin
22	XB16	2	Cotter pin 1/8" x 1"
23	XA1668	1	Safety lock block
24	XBNRJ34F	1	Jam nut
25	XA1674	1	Safety release arm
26	XBV919	1	1/2" diameter steel ball
27	XBV932	1	Compression spring
28	XBV1025	1	Set screw 5/8" - 18
29		1	Grease fitting
30		1	Roll pin
31		1	Lock pin bushing
32	XA1016	1	Hinged lock pin
33		1	Lock pin bushing
34		2	Grease fitting
35	XA2016	2	Bracket pin
36		2	Roll pin
37A	XB1604/5	2	Rubber bushing (for fifth wheels mfd. prior to 5/1/82)
37B		2	Rubber bushing kit (for fifth wheels mfd. after 5/1/82)
37C	XB0011/2	2	Rubber bushing (for fifth wheels mfd. after 6/1/87)
38	TF0110	1	Kingpin gauge
39	TF0237	1	2" dia. plug
40		1	Lock tester - 2" kingpin
41	XB02846	2	Washer (left hand only)
42	XA7822	2	Foot 185mm mounting height
	XA7824	2	Foot 135mm mounting height



# FLEETMASTER FW8TP (ASSY)

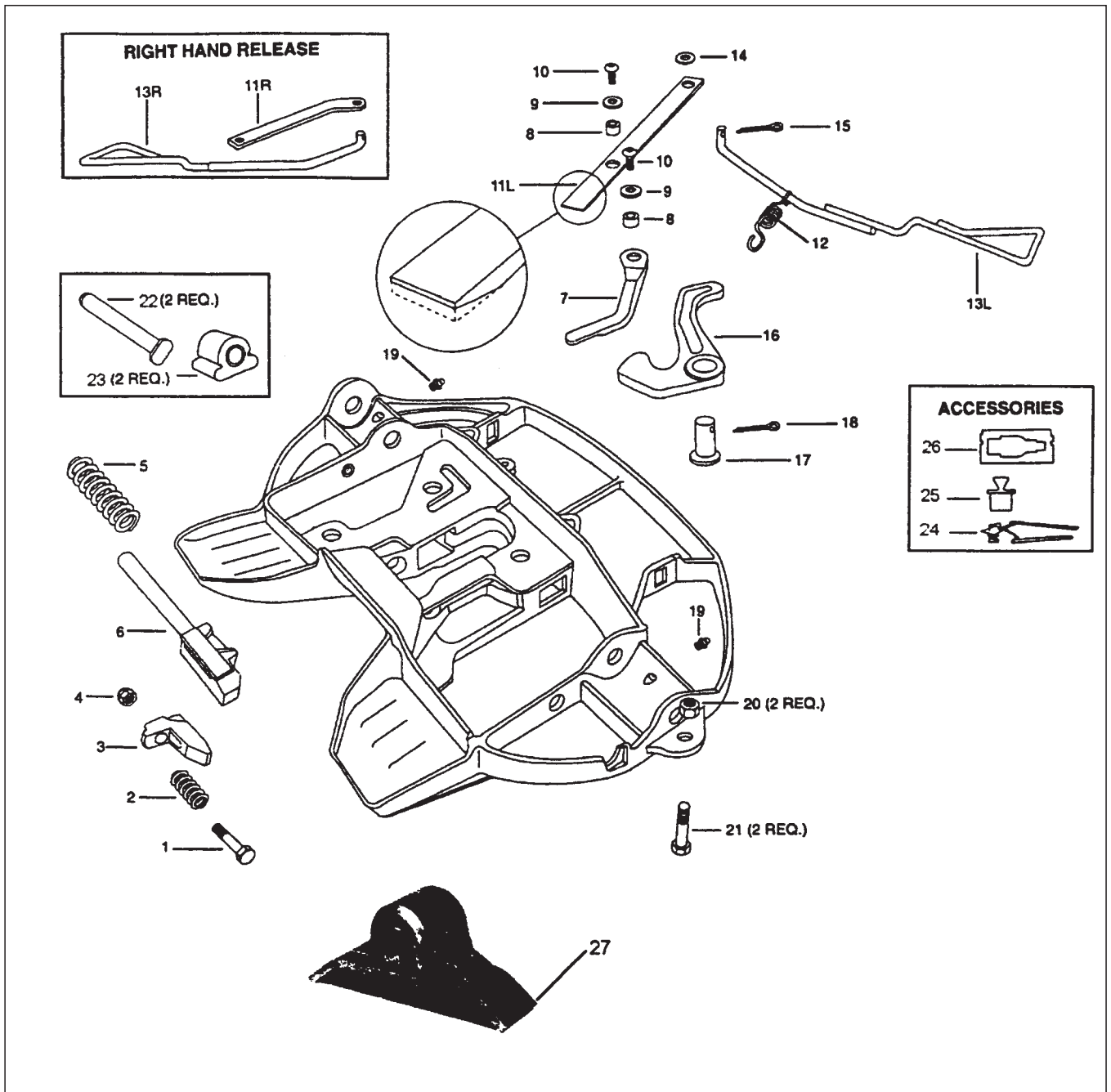



## FLEETMASTER FW8TP

ITEM	PART No.	No. REQUIRED	PART NAME
ASSY	XA201A	1	Top plate 5th wheel assy
1	XB06329	1	Bolt $\frac{5}{8}$ " - 11 x 4 - $\frac{1}{4}$ "
2	XB403	1	Spring
3	XD06328	1	Wedge adjuster
4	XB06179-1	1	Lock nut $\frac{5}{8}$ " - 11
5	XB06330	1	Spring
6	XA06846	1	Lock S/A plunger
7	XE06343	1	Arm cam
8	XA06332	2	Roller
9	XBT49	3	Washer $\frac{1}{2}$ "
10	XB06331	2	Bolt $\frac{1}{2}$ " - 13 x 1 - 1 $\frac{1}{4}$ "
11L	XA07388	1	Arm L/H release
11R	XA06334	1	Arm R/H release
12	XB06355/1	1	Extension spring
13L	XA06337	1	Handle L/H release
13R	XA06338	1	Handle R/H release
14	XBT199	1	Washer $\frac{5}{8}$ "
15	XB06336	1	Cotter pin $\frac{3}{16}$ " x 1 - $\frac{1}{4}$ "
16	XA06326	1	Lock hinged
17	XA06344	1	Lock pin
18	XB5	1	Cotter pin $\frac{1}{4}$ " x 2"
19	XBH38	2	Grease nipple
20	XBC95	2	Hex cap screw $\frac{1}{2}$ " x 1.25"
21	XBT69A	2	Locknut $\frac{1}{2}$ "
22	XE06356	2	Bracket pin
23	XB0011/2	2	Rubber bushing
24	TLN1000	1	2" Lock tester
25	TF0237	1	2" Lock gauge
26	TF0110	1	Kingpin gauge
27	XA7822	2	Foot 185mm mounting height
	XA7824	2	Foot 135mm mounting height
	XA7821	2	Foot 210mm mounting height



# FLEETMASTER XA-201 SERIES FIFTH WHEEL

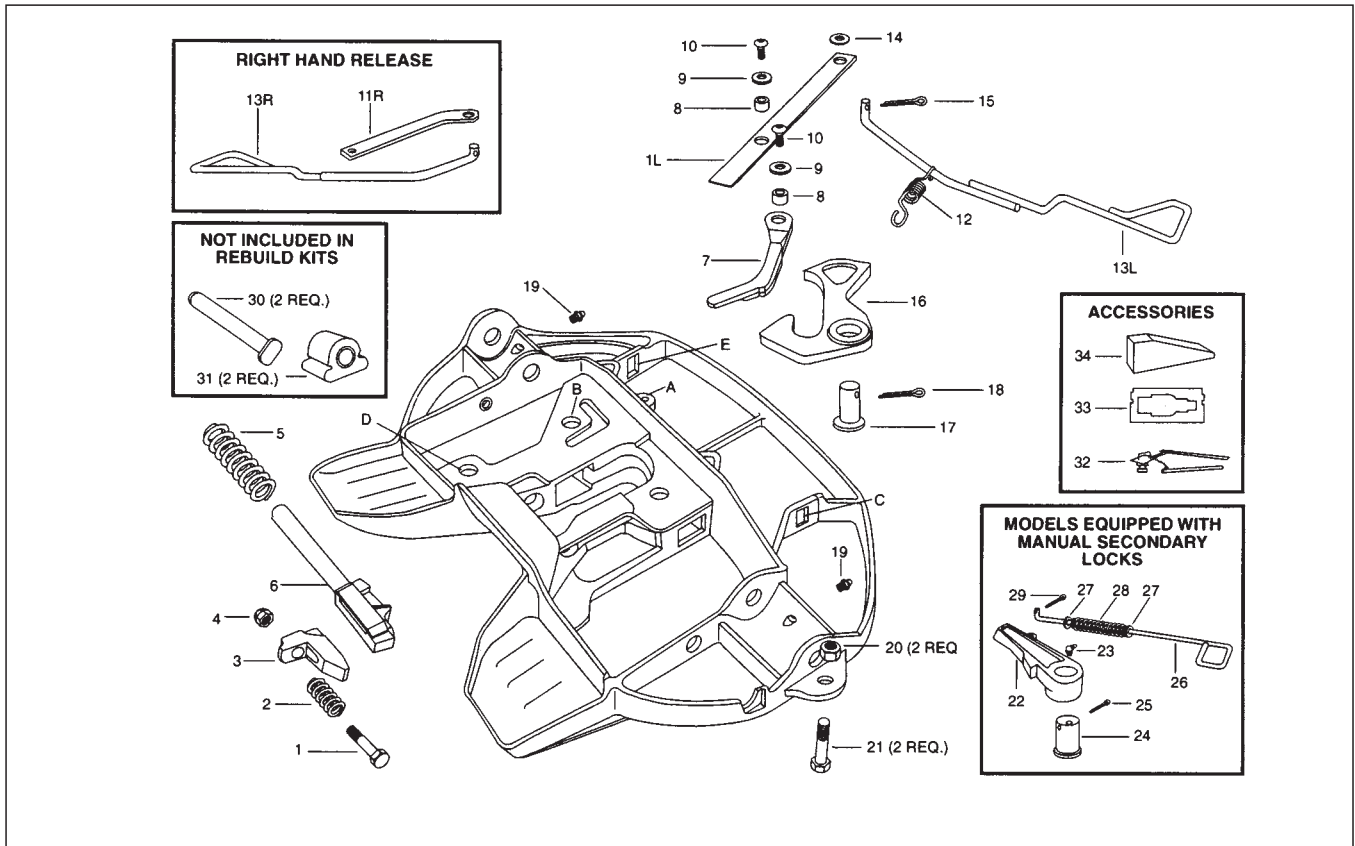

ITEM	PART No.	No. REQ'D	PART NAME	ITEM	PART No.	No. REQ'D	PART NAME
1	XB-06329	1	Hex hd. cap screw $\frac{5}{8}$ " - 11 x 4.25"	18	XB-5	1	Cotter pin .25" x 2"
2	XB-403	1	Spring	19	XB-H-38	2	Grease fitting
3	XD-06328	1	Adjusting wedge	20	XB-T-69-A	2	Locknut $\frac{1}{2}$ " -20
4	XB-06179-1	1	Locknut $\frac{5}{8}$ " - 11	21	XB-C-95	2	Hex hd. cap screw $\frac{1}{2}$ " -20 x 1.25"
5	XB-06330	1	Plunger spring	*22	XA-06349	1	Manual secondary lock arm
†6	XA-08081	1	Locking plunger	*23	XB-767-C	1	45° grease fitting
†7	XE-08113	1	Cam arm	*24	XA-1016-C	1	Secondary lock pin
8	XA-06332	2	Roller	*25	XB-5	1	Cotter pin .25" x 2" (same as #18)
9	XB-T-49	2	$\frac{1}{2}$ " washer	*26	XA-06345	1	Secondary lock release handle
10	XB-06331	2	"Torx" SBHCS $\frac{1}{2}$ " - 13 x 1.25	*27	XB-1204	2	$\frac{7}{16}$ " washer
11R	XA-06334	1	Right hand release arm	*28	XB-1028-1	1	Spring
11L	XA-07388	1	Left hand release arm	*29	XB-16	2	Cotter pin $\frac{1}{8}$ " x 1"
12	XB-06335-1	1	Extension spring	*30	XE-06356	2	Bracket pin
13R	XA-08548	1	Right hand release handle	*31	XB-0011-2	2	Rubber bushing
13L	XA-08546	1	Left hand release handle	*32	TF-TLN-1000	2	2" lock tester
14	XB-T-199	1	$\frac{5}{8}$ " washer	*33	TF-0110	1	Kingpin gauge
†15	XB-06336	1	Cotter pin 19" x 1.25"	*34	TF-TLN-08284	1	Assy. helper block
16	XA-08114	1	Hinged lock	*35	TF-TLN-5000	1	2" lock tester
17	XA-06344	1	Lock pin				

\* Not included in Rebuild Kit

† These parts must be ordered as a complete kit - P/N RK-201-08114 - (L or R)



## FW3500 SERIES TOP PLATE

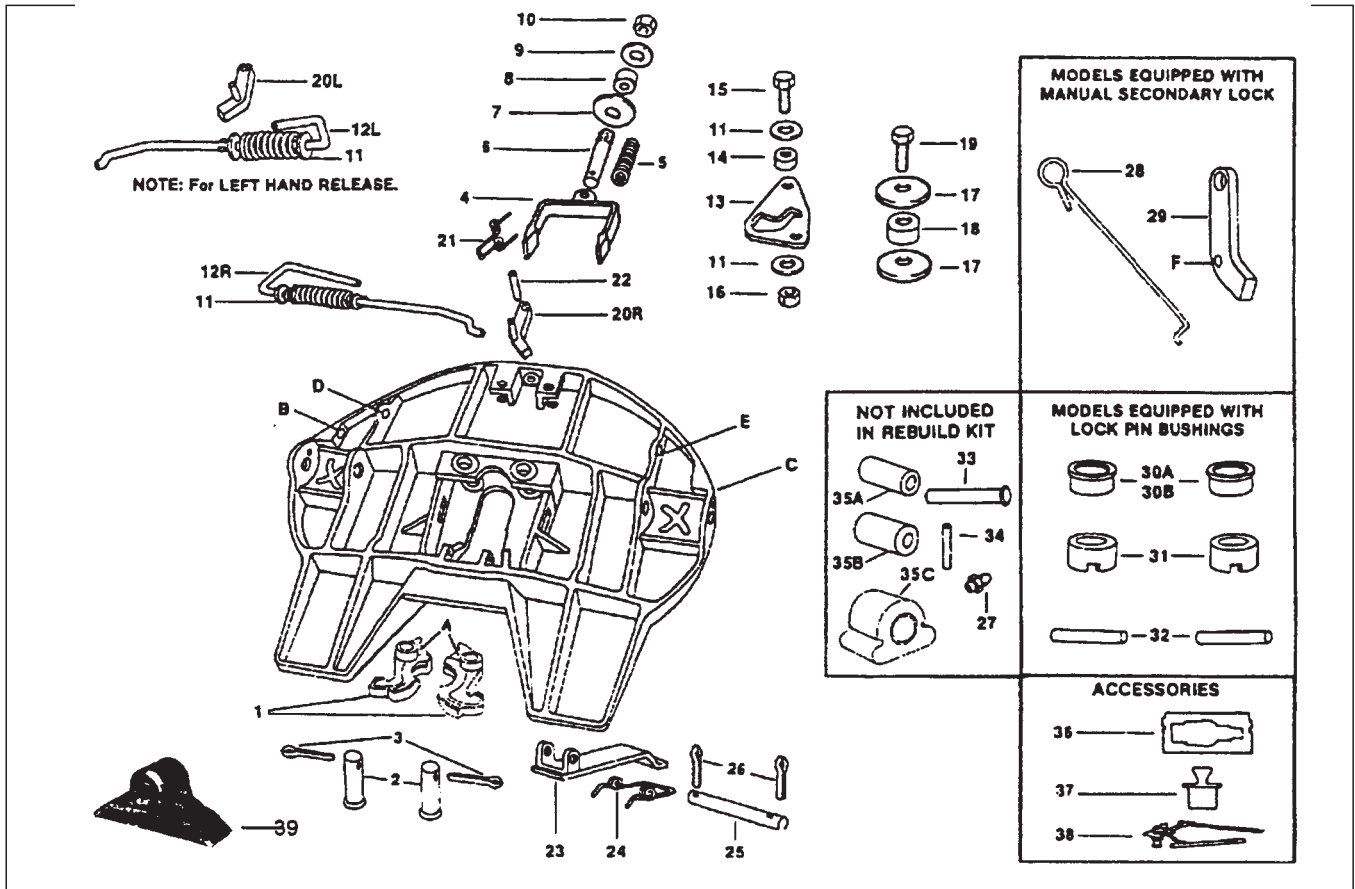

ITEM	PART No.	No. REQ'D	PART NAME	ITEM	PART No.	No. REQ'D	PART NAME
1	XA1704	1	Lock jaws	22		1	Roll pin
2	XA1313	2	Lock pin	23	XA3514	1	Lock guard
3	XB5	2	Cotter pin 1/4" x 2"	24	XB1044	1	Torsin spring
4	XA1703F	1	Yoke assembly	25	XA1055	1	Pin
5	XB1505	1	Spring	26	XB16	2	Cotter pin 1/8" x 1
6	XA1706	1	Yoke shaft	27	XBH38	2	Grease nipple
7		1	Lock adjustment tag	28	XA3542M	1	Manual secondary lock handle
8	XB1127	1	Rubber block	29		1	Manual secondary lock
9		1	Washer 1 1/2" O.D. x 13/16" I.D.	30		2	Lock pin bushing
10	XBHMH34F	1	Locknut 3/4" - 16	31		2	Lock pin bushing
11	XBT49	3	Washer 1 3/4" O.D. x 9/16"	32		2	Roll pin must be used with part No. 2 when wheel is equipped with lock pin bushings
12L		1	Left hand release sub assy.				
			(Part no. 11 must be installed on handle for complete assy.)				
12R	RK1707/6	1	Right hand release sub assy.	33	XA2016	2	Bracket pin
			(Part no. 11 must be installed on handle for complete assy.)	34		2	Roll pin
13	XA1705	1	Cam plate	35A		2	Rubber bushing (for fifth wheels mfd. prior to 5/82)
14	XA1029	1	Roller	35B		2	Rubber bushing no longer available
15	XB2083	1	Bolt 1/2" - 10 x 1 3/4"	35C	XB0011/2	2	Rubber bushing (for fifth wheels mfd. after 6/87)
16	XBT69A	1	Locknut 1/2" - 20				
17	XB1030/1	2	Washer	36	TF0110	1	Kingpin gauge
18	XA1507	1	Roller	37	TF0237	1	2" plug
19	XBCX58F134	1	Bolt 5/8" - 18 x 1 3/4"	38		1	Kingpin lock tester
20L		1	Secondary lock, left hand	39	XA7822	2	Foot 185mm Mntg height
20R	XA3542R	1	Secondary lock, right hand		XA7824	2	Foot 135mm Mntg height
21	XB2149	1	Torsion spring				



## 3500 XA-351 SERIES FIFTH WHEEL

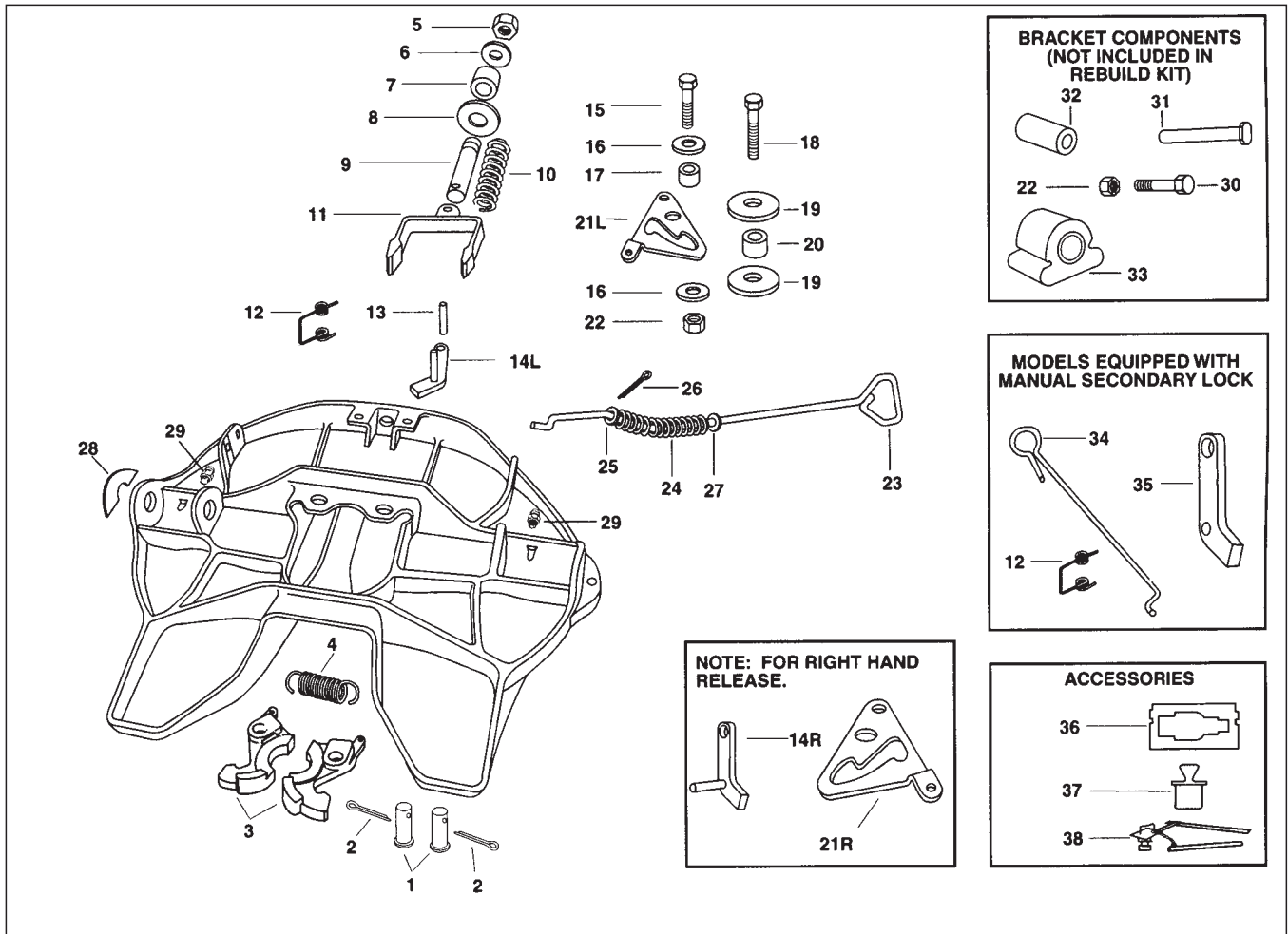

ITEM	PART No.	No. REQ'D	PART NAME	ITEM	PART No.	No. REQ'D	PART NAME
1	XA-07292-T	2	Lock Pin	20	XA-1507	1	Roller (3/8" I.D.)
2	XB-5	2	Cotter pin (1/4" x 2")	21L	XA-07150-L	1	Cam plate (left hand)
3	XA-07296	1	Lock jaw set	21R	XA-07150-R	1	Cam plate (right hand)
4	XB-07628	1	Extension spring	22	XB-T-69-A	1	Locknut (1/2"-20) 2 add'l. req'd for brackets
5	XB-HNH-34-F	1	Locknut (3/4"-16)	23	XA-07151-1	1	Release handle (universal for both left & right)
6	XB-PW-1316-112	1	Washer (1-1/2" O.D. x 13/16" I.D.)	24	XB-07291	1	Compression spring
7	XB-1127	1	Rubber washer	25	XB-PW-1732-1-116	1	Washer (1-1/16" O.D. x 5/8" I.D.)
8	XB-02312	1	Lock adjustment tag	26	XB-07508	1	Cotter pin (1/8" x 1-1/4")
9	XA-07679	1	Yoke shaft	27	XB-T-49	1	Washer (1-3/8" O.D. x 9/16" I.D.)
10	XB-1505	1	Compression spring	28	XB-07610	1	Operation tag
11	XA-07295	1	Yoke	29	XB-H-38	2	Grease zerk
12	XB-2149	1	Torsion spring	*30	XB-C-95	2	Hex head cap screw (1/2"-20 x 1-1/4")
13	XB-21-S-500-2750	1	Roll pin (1/2" x 2-3/4")	*31	XE-06356	2	Bracket pin
14L	XA-3542-L	1	Secondary lock (left-hand)	*32	XB-1604-5	2	Rubber bushing (brackets mfg'd prior to 5/82)
14R	XA-3542-R	1	Secondary lock (right hand)	*33	XB-0011-2	2	Rubber bushing (brackets mfg'd after 5/82)
15	XB-2083	1	Hex head cap screw (1/2"-20 x 1-3/4")	†34	XA-3542-M	1	Manual secondary lock release handle
16	XB-08559	2	Washer (1-3/4" O.D. x 9/16" I.D.)	†35	XA-3528	1	Manual secondary lock
17	XA-1029	1	Roller (1/2" I.D.)	*36	TF-0110	1	Kingpin gauge
18	XB-CX-58-F-134	1	Hex head cap screw (5/8"-18 x 1-3/4")	*37	TF-0237	1	2" Lock gauge (plug)
19	XB-07431	2	Washer (2-5/8" x 2 1/32")	*38	TF-TLN-1000	1	Kingpin lock tester

\* Parts not included in rebuild kit (available from your local Holland distributor)

† Parts included in rebuild kits RK-351-A-L-02 and RK-351-A-02



## SLIDE RELEASE FOR FW2090, FW3590, FW7090 SERIES

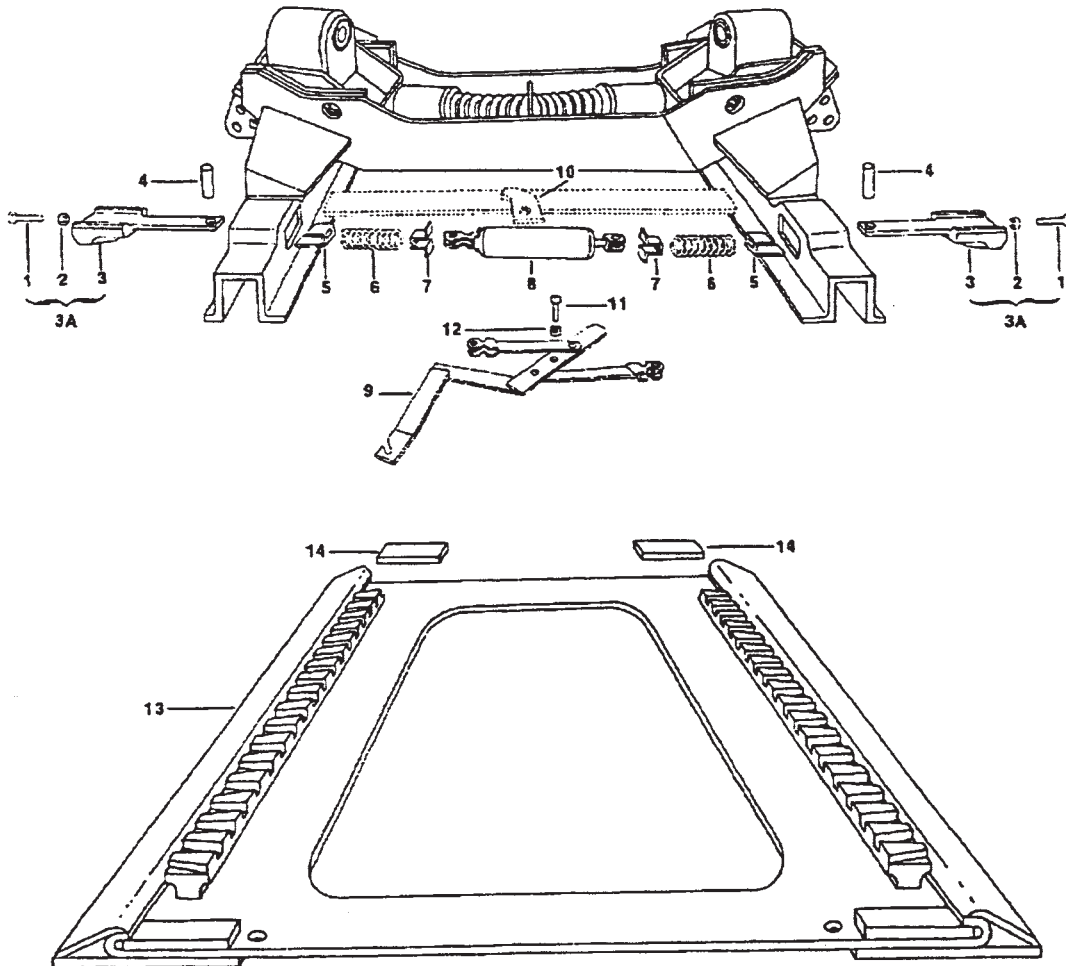

ITEM	PART No.	No. REQUIRED	PART NAME
1	XB0728	2	Hex bolt $\frac{3}{8}$ " 16 x 2"
2	XB0729	2	Jam nut $\frac{3}{8}$ " 16
3	XA0372	2	Plunger
4	XA2503	2	Pin
5	XA01586	2	Plate
6	XB2502	2	Spring
7	XA2501	2	Spring clip
8	XA2524	1	Air cylinder (air release)
9		1	Release lever assy (Man release)
10		1	Pivot bracket (Man release)
11		1	B H C S $\frac{1}{2}$ " 13 x 1.25"
12		1	Bushing
13	XA0284	1	Slide base 10 7" travel
14		2	Slide stops (shipping loose with slide base)



# SLIDING AND STATIONARY KOMPENSATOR SUBASSEMBLY FOR FW2090, FW3590, FW7090, FW3540, FW8KP, FW8KPAS SERIES

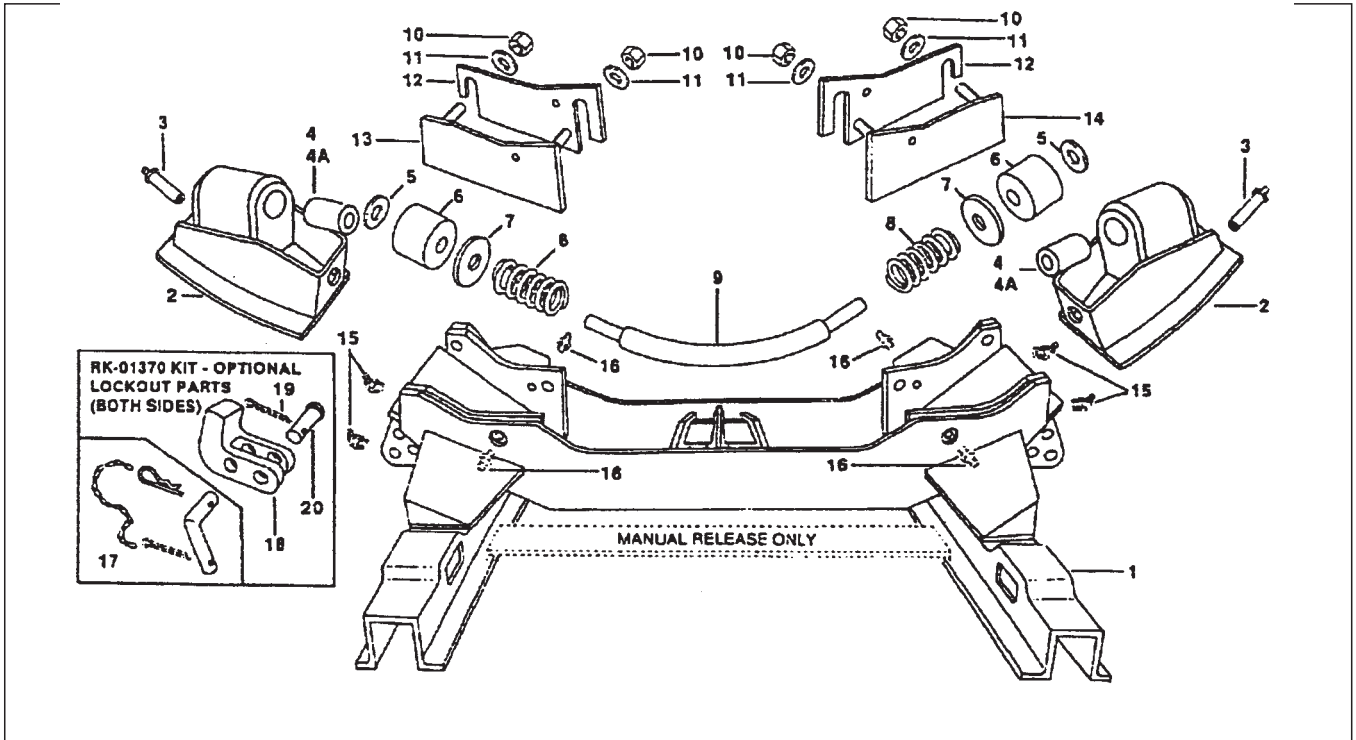

ITEM	PART No.	No. REQ'D	PART NAME	ITEM	PART No.	No. REQ'D	PART NAME
1		1	Kompensator frame	11		4	Lock washer 1/2"
2	XA0024	2	Shoe subassembly includes part No 3	12	XA0014	2	Shim (as required) late model
3	XBH38F	2	Grease fitting		XA87	2	Shim early model
4	XB0011	2	Rubber cushion (Series FW2540, FW2590, FW3590, FW3540, FW8KP, FW8KPAS Series)	13	XA01997	1	Bearing plate RH
4A	XB0012	2	Rubber cushion (Series FW7040, FW7090)		XA87	1	Bearing plate early model
		2	Washer	14	XA01998	1	Bearing plate LH
6	XB0009	2	Cushion		XA87	1	Bearing plate early model
7	XA1284/2	2	Washer	15	XBH38C	4	45 grease fitting
8	XB01923	2	Spring	16		4	Grease fitting
9	XA39	1	Tie Bar	17		2	"L" pin sub assembly
10		4	Hex nut 1/2" 13	18		2	Lockout stop
				19		2	Cotter pin 19" x 1.25
				20		2	Shackle pin