

SPICER / STD FORGE / INGERSOL

BRAKE REPAIR KITS SPICER (DANA) 12¹/₄" NEW STYLE "U" BRAKE

APPLICATION		KIT NUMBER
<p>For use with Old Style "Fast-Rise" Camshafts only.</p>		<p>EUCLID KIT Z-E3782</p> <p>Includes:</p> <ul style="list-style-type: none"> 2 Z-E5304 Hard Chrome Anchor Pin 2 Z-E586 Knurled Roller 2 Z-E539 Roller Retainer 1 Z-E2398 Return Spring 2 Z-E747 Spring Retainer 1 Z-E5305 Retainer Clip

SPICER (DANA) 12¹/₄" OLD STYLE "U" BRAKE

APPLICATION		KIT NUMBER
		<p>EUCLID KIT Z-E5306</p> <p>Includes:</p> <ul style="list-style-type: none"> 2 Z-E5304 Hard Chrome Anchor Pin 2 Z-E2395 Knurled Roller 2 Z-E2396 Roller Pin 1 Z-E2398 Return Spring 2 Z-E2399 Spring Retainer 2 Z-E527 Lock Ring 1 Z-E5305 Retainer Clip

STD FORGE 12¹/₄" BRAKE WITH FABRICATED SHOES

APPLICATION		KIT NUMBER
<p>Replaces Spicer (Dana) M12LK101X</p>		<p>EUCLID KIT Z-E2402HD</p> <p>Includes:</p> <ul style="list-style-type: none"> 2 Z-E2390 Hard Chrome Anchor Pin 4 Z-E2391 Washer 4 Z-E2392 Lock Ring 2 Z-E2395 Knurled Roller 2 Z-E2396 Roller Pin 2 Z-E527 Lock Ring 1 Z-E2398 Return Spring 2 Z-E2399 Spring Retainer 2 Z-E2389 Stainless Steel Anchor Pin Bushing

"UNIVERSAL" KIT WITH "FREE-FLOATING" ANCHOR PIN USED ON 16¹/₂" EATON, FRUEHAUF, ROCKWELL, SPICER (DANA) AND STD. FORGE BRAKES

APPLICATION INFORMATION		KIT NUMBER
<p>All 16¹/₂" P brakes on truck, tractor and trailer axles with fab shoes. Contains phosphate coated anchor pins. Services one brake</p>		<p>EUCLID KIT Z-R509000</p> <p>Includes:</p> <ul style="list-style-type: none"> 2 Z-1259M1131 Anchor Pin 1 Z-2258P354 Return Spring 2 Z-1779R18 Roller 2 Z-1225B496 Anchor Pin Bushing 2 Z-1218G85 Return Spring Pin 2 Z-1718Y103 Roller Retainer 4 Z-1229D2942 Snap Ring 4 Z-1229B1848 Anchor Pin Washer

SPICER / STD FORGE / INGERSOL

ROCKWELL 16 1/2" "Q", "Q PLUS" AND SPICER (DANA) "FAST CHANGE" BRAKE

APPLICATION INFORMATION		KIT NUMBER
Services all Q brake sizes, incl. Fruehauf, exc. those on front steering axles. Services one brake.		EUCLID KIT Z-KIT8000 Includes: 2 Z-1259N274 Anchor Pin 1 Z-2258U619 Return Spring 2 Z-2258Q615 Retainer Spring 2 Z-1779R18 Roller 2 Z-1225B496 Anchor Pin Bushing 2 Z-1218G85 Return Spring Pin 2 Z-3105B210 Roller Retainer

BRAKE SHOE ROLLERS "Hi-Kromite Plated"

"POSI-ROLL" DIAMOND KNURLED BRAKE SHOE ROLLERS For Fabricated Brake Shoes	PART No.	REPLACES	O.A. LENGTH	LENGTH OF LARGE DIA.	O.D.	APPLICATION & GENERAL INFORMATION
	Z-E2177	Rockwell 1779R18 Diamond T 26282 Fruehauf 330733 GM 2295551 Spicer M16WJ104 Std. Forge 204101-001 Trailmobile 7-23-7 WhiteGMC 827702	2 7/32"	1 9/32"	1 1/4"	For 16 1/2" Brakes with Fabricated Brake Shoes

BRAKE SHOE ANCHOR PINS

HARD CHROME PLATED	PART No.	REPLACES	LENGTH	O.D.	APPLICATION & GENERAL INFORMATION
	Z-E512BK	Rockwell 1259-Q-251 Fruehauf 330673 GM 2295423 Kershaw 11093 Mack 3015M-86 Navistar 126403R1 Spicer M10WJ162 Std. Forge 203102-001	2 7/8"	1 1/4"	For Rockwell & Fruehauf Fabricated Shoes

HARD CHROME PLATED	PART No.	REPLACES	LENGTH	O.D.	APPLICATION & GENERAL INFORMATION
	Z-E609	Rockwell 1259-N-170 Fruehauf 578322 Spicer M10WJ164 Std. Forge 203106	2 15/32"	1 1/4"	For Rockwell & Fruehauf "Pro-Par" axle with Fabricated Shoes

BRAKE SHOE RETURN SPRINGS

FOR 16 1/2" BRAKES	PART No.	REPLACES	O.A. LGTH	O.D.	APPLICATION & GENERAL INFORMATION
 HEAVY-DUTY 100 lb. MEGA PLUS SPRING	Z-E1880B RED	Rockwell 2258-Z-416	8"	1 1/4"	Heavy-Duty version Use for Spicer "XL" Brakes and Rockwell "P" Brakes

SPICER / STD FORGE / INGERSOL

CAM BRAKE SHOES - 12 1/4" DIA. BRAKES

STANDARD FORGE
Heavy-Duty Version for Severe Service



PART No.	REPLACES	SIZE	FMSI No.	RIVET
Z-E2394	Spicer M12WS127 Std. Forge 201140	12 1/4" x 7 1/2"	4591	20-8

SPICER & STANDARD FORGE
"U" BRAKE



PART No.	REPLACES	SIZE	FMSI No.	RIVET
Z-E5303A	Spicer M12WS149X Spicer (Old) M12WS129X Std. Forge 204102	12 1/4" x 7 1/2"	4692	10-8

DUST SHIELDS FOR MULTI-PURPOSE TRAILER APPLICATIONS



BRAKE SIZE	PART No.	REPLACES
16 1/2" x 6" 16 1/2" x 7"	Z-E886 STEEL	Eaton B-1688A Fruehauf 966691LH 966692RH Rockwell 3236-A-1249LH 3236-B-1250RH A1-3236-A-1249 Spicer M16WB101 Std. Forge UB1172, UB1165 & 5102

BRAKE CAMSHAFTS FOR SPICER (STD. FORGE) TRAILER AXLES WITH 12 1/4" BRAKES

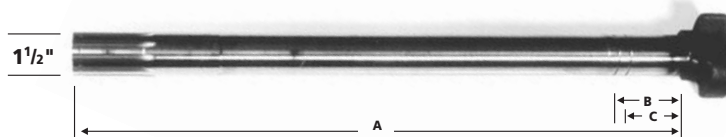

1 1/2" Dia. - 10 Spline
Length shown is from under
Cam Head to beginning of
Lock Ring Groove.

PART No.	REPLACES	A	B	C	APPLICATION & GENERAL INFORMATION
Z-E1411 LH	Std. Forge 202103-213LH, UB22-64L Spicer M12WK107-6	21 1/8"	2 7/32"	2 21/32"	Spicer (Dana) & Std. Forge 12 1/4" x 5 1/2" & 12 1/4" x 7 1/2" Brakes
Z-E1410 RH	Std. Forge 202103-213RH, UB22-64R Spicer M12WK106-6				
Z-E1423 LH	Std. Forge 202103-233LH, UB24-15L Spicer M12WK101-17	23 1/4"	2 7/32"	2 21/32"	
Z-E1422 RH	Std. Forge 202103-233RH, UB24-15R Spicer M12WK100-17				

BRAKE CAMSHAFTS

**1 1/2" DIAMETER MULTI-APPLICATION CAMSHAFTS FOR TRAILERS
WITH 16 1/2" BRAKES - Double Groove**

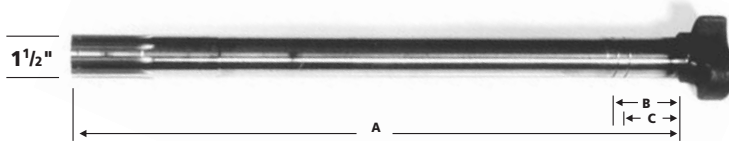

1 1/2" Dia. - 10 Spline
Length shown is from under
Cam Head to beginning of
Lock Ring Groove.

PART No.	REPLACES	A	B	C	APPLICATION & GENERAL INFORMATION
Z-E1425 LH	Rockwell Fruehauf Spicer Std. Forge Trailmobile 2210-N-2484 & 2210-G-3595 219316 & 580443 M16WK103-17 202100-205L 7-5-64L	20 ³ / ₈ "	2 ⁷ / ₃₂ "	1 ⁵ / ₈ "	"Standard" Universal 1 ⁵ / ₈ " Groove used on Paymaster RN & RL Axles
Z-E1424 RH	Rockwell Fruehauf Spicer Std. Forge Trailmobile 2210-M-2483 & 2210-F-3594 219317 & 580444 M16WK102-17 202100-205R 7-5-64R				
Z-E1095 LH	Eaton Std. Forge Spicer F-1691-25 202100-236L M16WK103-25	23 ⁷ / ₁₆ "	2 ⁵ / ₁₆ "	2 ⁷ / ₃₂ "	Extra long for use with Air Ride Suspensions Extra length keeps slack adjuster from rubbing on air bags and causing premature rupture
Z-E1094 RH	Eaton Std. Forge Spicer B-1691-26 202100-236R M16WK102-25				

CAMSHAFT REPAIR KITS FOR 12 1/4" DIA. BRAKES

APPLICATION		KIT NUMBER
<p>For late model Spicer & Standard Forge Axles</p> <p>Replaces Spicer M12KY101</p>		<p>EUCLID KIT Z-E2469</p> <p>Includes:</p> <ul style="list-style-type: none"> 2 Z-E580 Washer 2 Z-E581 Washer 4 Z-E1416A Seal 2 Z-E2404 Washer 4 Z-E526 Lock Ring 2 Z-E759 Bushing 2 Z-E2102 Bushing 2 Z-E2409 Washer

FOR 16 1/2" DIA. CAM BRAKES

APPLICATION		KIT NUMBER
<p>For Spicer & Standard Forge late model A-17S, A-19SA22-S Axles</p> <p>With Weld-on Spiders</p> <p>Replaces Spicer M16KY20</p>		<p>EUCLID KIT Z-E2287</p> <p>Includes:</p> <ul style="list-style-type: none"> 4 Z-E1416A Seal 2 Z-E719 Washer 2 Z-E759 Bushing 2 Z-E2102 Bushing 4 Z-E526 Lock Ring 2 Z-E2409 Washer 2 Z-E580 Washer 2 Z-E5093 Lock Ring 2 Z-E801 Lock Ring 4 Z-E1113 Washer

CAMSHAFT BUSHINGS

NYLON



PART No.	O.D.	I.D.	LENGTH
Z-E759	1 7/8"	1 1/2"	1 1/2"
	Replaces: Spicer M10WJ118 Std. Forge 405129		

MOLYBDENUM



PART No.	O.D.	I.D.	LENGTH
Z-E1365	1 7/8"	1 1/2"	1 1/2"
	Molybdenum Disulfide Version of E-759 & E-807 For On-Highway Use Only		

NYLON



PART No.	O.D.	I.D.	LENGTH
Z-E2102	2 15/32"	1 1/2"	1 3/4"
	Replaces: Spicer M10WJ107 Std. Forge 405128		

TRAILER AXLE SPINDLE NUTS

ROCKWELL, EATON, KERSHAW, & STD. FORGE 17,000 & 18,000 LB. TRADE AXLES



INNER NUT



OUTER NUT



LOCK WASHER

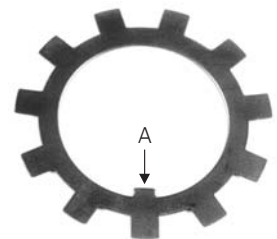

TAB LOCK

DESCRIPTION	PART No.	REPLACES	ACROSS FLATS	THREAD SIZE	THICKNESS	O.D.	I.D.
INNER NUT	Z-E540	Eaton 820394 Spicer M10HN101 Std. Forge 103103-002 Rockwell 1227-C-549	3 13/16"	2 5/8" -16	3/8"	-	-
OUTER NUT	Z-E572	Eaton 820395 Spicer M10HN102 Std. Forge 103102-001 Rockwell 1227-B-756	3 1/4"	2 5/8" -16	3/8"	-	-
LOCK WASHER	Z-E573	Eaton 820396 Spicer M10HN100 Std. Forge 105107 Rockwell 1229-V-1660	NOTE: Used With All Standard Depth Axle Keyway (long hub)		1/4"	3 15/16"	2 41/64"
TAB LOCK	Z-E2237	Std. Forge 105106	A = 5/32" long		.060	4 1/32"	2 41/64"

SPICER / STD FORGE / INGERSOL

ROCKWELL, SPICER & STD. FORGE 11,000 LB. AXLES



DESCRIPTION	PART No.	REPLACES	ACROSS FLATS	THREAD SIZE	THICKNESS	O.D.	I.D.
LOCK WASHER	Z-E1000	Rockwell 1229-T-462 Spicer M10HN130 Std. Forge 105109	-	-	.062	2 ⁷ / ₈ "	1 ¹ / ₂ " x 1 ³ / ₈ " D Hole

TRAILER AXLE SPINDLE NUTS

SPICER D21 & D22, & STD. FORGE A25 & A26 AXLES



INNER NUT



OUTER NUT



LOCK WASHER



TAB LOCK

DESCRIPTION	PART No.	REPLACES	ACROSS FLATS	THREAD SIZE	THICKNESS	O.D.	I.D.
INNER NUT	Z-E540	Spicer M10HN158 Std. Forge 103104-001	4 ¹ / ₂ "	2 ⁵ / ₈ " -16	1 ¹ / ₃₂ "	-	-
OUTER NUT	Z-E572	Spicer M103102-001 Std. Forge 103102-001	3 ¹ / ₄ "	2 ⁵ / ₈ " -16	³ / ₈ "	-	-
LOCK WASHER	Z-E573	Spicer M10HN100 Std. Forge 105107	-	-	¹ / ₄ "	3 ¹⁵ / ₁₆ "	1 ⁴¹ / ₆₄ "
TAB LOCK	Z-E2237	Spicer M10HN151 Std. Forge 105106	-	-	.060	4 ¹ / ₃₂ "	2 ⁴¹ / ₆₄ "