

# TRAILER COMPONENTRY

• Fruehauf.....	1
• Hutchens.....	9
• Navistar International.....	13
• Reyco.....	14
• Rockwell.....	19
• Spicer/Std Forge/Ingersol.....	27
• York & Moss.....	33
• Trailer Springs.....	34
• Air Suspension.....	38
• Truck & Trailer Air Spring Applications....	39
• Stemco Hub Caps.....	41
• Trailer Axle Componentry Chart.....	42
• Bearings, Seals, Hub Caps.....	44
• Bearings, Seals, Hub Caps Applications....	45

# S E C T I O N



# A

# FRUEHAUF

## RETAINERS

RETAINER	PART No.	REPLACES	SPECIFICATIONS	APPLICATION & GENERAL INFORMATION
	Z-E3227	Fruehauf ACF-1328-001	-	For all "Pro-Par" Axles with 16 1/2" Brakes including "XEM"

## BRAKE SHOE ANCHOR PINS

HARD CHROME PLATED	PART No.	REPLACES	LENGTH	OD	APPLICATION & GENERAL INFORMATION
	Z-E512BK	Rockwell 1259-Q-251 Fruehauf 330673 GM 2295423 Kershaw 11093 Mack 3015M-86 Navistar 126403R1 Spicer M10WJ162 Std. Forge 203102-001	2 7/8"	1 1/4"	For Rockwell & Fruehauf Fabricated Shoes

HARD CHROME PLATED	PART No.	REPLACES	LENGTH	OD	APPLICATION & GENERAL INFORMATION
	Z-E609 Only available in kit Z-E2286	Rockwell 1259-N-170 Fruehauf 578322 Spicer M10WJ164 Std. Forge 203106	2 15/32"	1 1/4"	For Rockwell & Fruehauf "Pro-Par" axle with Fabricated Shoes

## BRAKE SHOE ROLLERS "Hi-Kromite Plated"

"POSI-ROLL" DIAMOND KNURLED BRAKE SHOE ROLLERS For Fabricated Brake Shoes	PART No.	REPLACES	O.A. LENGTH	LENGTH OF LARGE DIA.	OD	APPLICATION & GENERAL INFORMATION
	Z-E2177	Rockwell 1779R18 Diamond T 26282 Fruehauf 330733 GM 2295551 Spicer M16WJ104 Std. Forge 204101-001 Trailmobile 7-23-7 WhiteGMC 827702	2 7/32"	1 9/32"	1 1/4"	For 16 1/2" Brakes with Fabricated Brake Shoes

## BRAKE REPAIR KITS FRUEHAUF "PRO-PAR" 12 1/4" BRAKE

	MEGA KIT No.	APPLICATION & GENERAL INFORMATION
	<b>EUCLID Z-E2286</b>  Includes: 2 Z-E609 Hard Chrome Anchor Pin 2 Z-E626 Roll Pin* 2 Z-E920 Stainless Steel Anchor Pin Bushing 2 Z-E747 Spring Retainer 2 Z-E1581 Roller Retainer 2 Z-E1582 Roller 1 Z-E1583 Return Spring  * (not sold separately)	For use with the following Brake Shoe:  E-1580 (8")

# FRUEHAUF

## BRAKE REPAIR KITS FRUEHAUF "PRO-PAR" 16 1/2" BRAKES

	MEGA KIT No.	APPLICATION & GENERAL INFORMATION
	<b>EUCLID Z-E2121HD</b>  Includes: 2 Z-E609 Hard Chrome Anchor Pin 2 Z-E626 Roll Pin* 2 Z-E920 Stainless Steel Anchor Pin Bushing 2 Z-E3227 Roller Retainer 2 Z-E2177 Knurled Roller 1 Z-E1880B Heavy-Duty Return Spring 2 Z-E747 Spring Retainer  * (not sold separately)	Replaces Fruehauf ACC-001996-902  For Old Style Spiders drilled for Roll Pin. For New Style Spiders not drilled for Roll Pin, use Meritor Kit Z-R509000.  For use with the following Brake Shoe: Z-E2685 (7")

## CAM BRAKE SHOES - 16 1/2" DIA. BRAKES

FRUEHAUF	UNLINED SHOE No.	REPLACES	SIZE	FMSI No.	RIVET	USE BRAKE REPAIR KIT
	Z-E2685	Fruehauf ACE-006184-001 514958-001 514961-900 Rockwell 3222-S-71	16 1/2" x 7"	4515E	10-8	Z-E2121HD, Z-E1816SHD

## BRAKE CAMSHAFTS

### FOR FRUEHAUF "PRO-PAR" TRAILER AXLES WITH 12 1/4" BRAKES

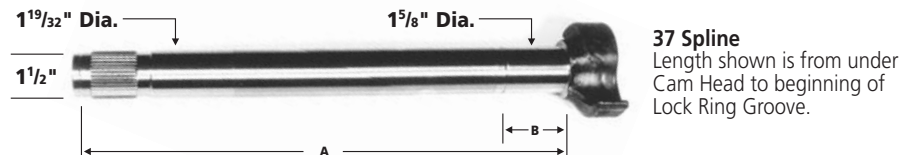

PART No.	REPLACES	A	B	APPLICATION & GENERAL INFORMATION
Z-E1585 LH	Fruehauf ACD-2193-2	16 1/8"	2 5/32"	-
Z-E1584 RH	Fruehauf ACD-2193-1			
Z-E4890 LH	Fruehauf ACD-2193-6	21 3/16"	2 5/32"	-
Z-E4891 RH	Fruehauf ACD-2193-5			

### FOR FRUEHAUF "PRO-PAR" AXLE WITH 16 1/2" BRAKES

PART No.	REPLACES	A	B	APPLICATION & GENERAL INFORMATION
Z-E1563 LH	Fruehauf AXA-0420-1	16 1/8"	2 5/32"	For "Pro-Par" Axle 16 1/2" Brakes. Use with Z-E1574BK 37 Serration Slack Adjuster.
Z-E1564 RH	Fruehauf AXA-0420-2			
Z-E2099 LH	Fruehauf AXA-0420-3	21 1/8"	2 5/32"	For 16 1/2" Fruehauf Brakes. Extra long for use with Air Ride Suspension. Use with Z-E1574BK 37 Serration Slack Adjuster.
Z-E2100 RH	Fruehauf AXA-0420-4			

# FRUEHAUF

## CAMSHAFT REPAIR KITS FOR 16 1/2" Dia. Cam Brakes

APPLICATION		KIT NUMBER																		
<p><b>FOR LATE MODEL FRUEHAUF "PRO-PAR" AXLES WITH 16 1/2" BRAKES</b></p> <p>Also used on 12 1/4" Brakes</p> <p>Replaces Fruehauf AXA-0420-900</p>		<p><b>EUCLID KIT Z-E2090</b></p> <p>Includes:</p> <table border="0"> <tr><td>4</td><td>Z-E1567</td><td>Bushing</td></tr> <tr><td>2</td><td>Z-E1577A</td><td>Bushing</td></tr> <tr><td>6</td><td>Z-E1565</td><td>Spacer Washer</td></tr> <tr><td>2</td><td>Z-E580</td><td>Spacer Washer</td></tr> <tr><td>2</td><td>Z-E1569</td><td>Lock Ring</td></tr> <tr><td>2</td><td>Z-E526</td><td>Lock Ring</td></tr> </table>	4	Z-E1567	Bushing	2	Z-E1577A	Bushing	6	Z-E1565	Spacer Washer	2	Z-E580	Spacer Washer	2	Z-E1569	Lock Ring	2	Z-E526	Lock Ring
4	Z-E1567	Bushing																		
2	Z-E1577A	Bushing																		
6	Z-E1565	Spacer Washer																		
2	Z-E580	Spacer Washer																		
2	Z-E1569	Lock Ring																		
2	Z-E526	Lock Ring																		

APPLICATION		KIT NUMBER																		
<p><b>FOR EARLY MODEL FRUEHAUF "PRO-PAR" AXLES</b></p> <p>Replaces Fruehauf 305680-900</p>		<p><b>EUCLID KIT Z-E2122</b></p> <p>Includes:</p> <table border="0"> <tr><td>4</td><td>Z-E1567</td><td>Camshaft Bushing</td></tr> <tr><td>2</td><td>Z-E1571</td><td>Support Bushing</td></tr> <tr><td>2</td><td>Z-E580</td><td>Spacer Washer</td></tr> <tr><td>6</td><td>Z-E1565</td><td>Spacer Washer</td></tr> <tr><td>2</td><td>Z-E1569</td><td>Lock Ring</td></tr> <tr><td>2</td><td>Z-E526</td><td>Lock Ring</td></tr> </table>	4	Z-E1567	Camshaft Bushing	2	Z-E1571	Support Bushing	2	Z-E580	Spacer Washer	6	Z-E1565	Spacer Washer	2	Z-E1569	Lock Ring	2	Z-E526	Lock Ring
4	Z-E1567	Camshaft Bushing																		
2	Z-E1571	Support Bushing																		
2	Z-E580	Spacer Washer																		
6	Z-E1565	Spacer Washer																		
2	Z-E1569	Lock Ring																		
2	Z-E526	Lock Ring																		

## CAMSHAFT BUSHINGS

NYLON				
				
PART No.	REPLACES	O.D.	I.D.	LENGTH
Z-E1571	Replaces: Fruehauf AXA-0429-900 For "Pro-Par" Axle	2 7/8"	1 19/32"	2 1/2"

NYLON				
				
PART No.	REPLACES	O.D.	I.D.	LENGTH
Z-E1577A	Replaces: Fruehauf ACD-2285-900	2 1/2"	1 19/32"	1 1/2"

### FOR FRUEHAUF "PRO-PAR" AXLE

	DESCRIPTION	PART No.	REPLACES	I.D.	APPLICATION
 WHITE	BUSHING	Z-E1567	Fruehauf AXA-0413-900	1 5/8"	Use 2 Bushings per Spider

# FRUEHAUF

## CAMSHAFT SPACER WASHERS

	PART No.	REPLACES	O.D.	I.D.	THICK	PLATED	APPLICATION
	Z-E581	Rockwell 1229-Q-771 Fruehauf 219292 Trailmobile 7-9-11	2 1/4"	1 17/32"	.032	YES	Used on all 1 1/2" dia. Camshafts
Z-E580	Rockwell 1229-R-122 Fruehauf 219293 Eaton AXA-0432-1 B-1216 & 820009	2 1/4"	1 17/32"	.060	YES	Use on all 1 1/2" dia. Camshafts Including End Washer for Fruehauf "Pro-Par" Camshaft	

## CAMSHAFT LOCK RINGS

	PART No.	REPLACES	I.D.	THICK	APPLICATION
	Z-E526	Rockwell 1229-Z-1118 Fruehauf 219160 Eaton B-1716 & 820095 GM 2101124	1 31/64"	1/16"	For all 1 1/2" dia. Camshafts

## DUST SHIELDS

### FOR MULTI-PURPOSE TRAILER APPLICATIONS

	PART No.	BRAKE SIZE	REPLACES
	Z-E886 STEEL	16 1/2" x 6" 16 1/2" x 7"	Eaton B-1688A Fruehauf 966691LH 966692RH Rockwell 3236-A-1249LH 3236-B-1250RH A1-3236-A-1249 Spicer M16WB101 Std.Forge UB1172, UB1165 & 5102

## MANUAL SLACK ADJUSTERS

	PART No.	REPLACES	FITS CAM SPLINE	ARM LENGTH	MAX. TORQUE RATING	APPLICATION & GENERAL INFORMATION
	Z-E1574BK	Bendix 283411 Eagle A-7100 Fruehauf ACF-000015-001 ACF-006404-002 Midland KN44041 Rockwell R822007 Sloan 2012	1 5/8" -37	6"	26,000lbs.	-

# FRUEHAUF

## WHEEL HUB CAPS

	PART No.	DESCRIPTION	REPLACES	THREAD SIZE	
	Z-E04075	HUB CAP	-	6¼" - 8	
	Z-E04075H	HUB CAP For use with Hubodometers	-	6¼" - 8	
	Z-E05500	"O" RING	-	O.D.	I.D.
Z-E04000	FILLER PLUG	-	6"	5½"	
					-

## WHEEL BEARING LOCK-NUT WRENCH

	<p><b>Z-E1597A</b> <b>HEAVY DUTY SPINDLE NUT WRENCH</b> For Fruehauf "Pro-Par" Spindle Nuts and Hub Caps. New design is made of high strength heavy 5/32" gauge steel to resist rounding out, splitting and twisting. 8 point, 4<sup>13</sup>/<sub>16</sub>" across flats, 2<sup>7</sup>/<sub>8</sub>" deep. 3/4" square drive opening allows for the use of a torque wrench and extensions. Replaces: Fruehauf ACC-005963-900</p>	<p><b>ONE WRENCH USED FOR BOTH</b></p> <p>Z-E2550 Spindle Nut</p> 
		 <p>Z-E04075 Hub Cap</p>

## TRAILER AXLE SPINDLE NUTS



PART No.	DESCRIPTION	REPLACES	ACROSS FLATS	THREAD SIZE	THICKNESS	WASHERS	
						O.D.	I.D.
Z-E2550	SPINDLE NUT	Fruehauf ACE-008510-001	4¾"	3½"	1⅛"	-	-
Z-E1561	LOCK WASHER	Fruehauf AXA-0408-1	-	-	.225	5⅛"	3½"

## FRUEHAUF "F" SERIES AXLE ATTACHING PARTS

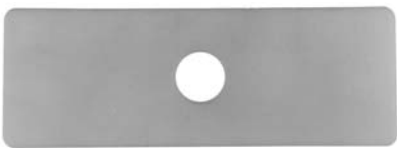
<p><b>DELFIN LINER BOTTOM PAD</b></p>  <p>Bottom pad has hole for centre bolt</p>	PART No.	REPLACES	FOR MODEL	APPLICATION
	Z-E2842	Fruehauf UCD-006632-002	F-1 F-2 F-2W F-3	For Single Leaf Springs Only

# FRUEHAUF

## FRUEHAUF TORQUE ARMS & BUSHING ASSEMBLY

TORQUE ARM BOLT

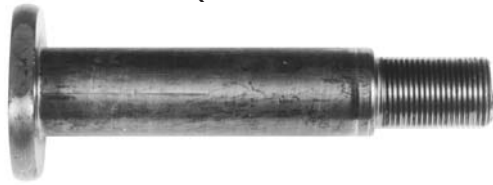

PART No.	REPLACES	THREAD	LENGTH
Z-E1018	Fruehauf UXA-000016	1"-14	6"

NUT



PART No.	REPLACES	THREAD	HEX	HIGH
Z-E937	Fruehauf FSP-006-02-PK9	1"-14	17/16"	7/8"

## FRUEHAUF TORQUE ARMS & BUSHING ASSEMBLY

COMPRESSION WASHER



PART No.	REPLACES	O.D.	I.D.	THICK
Z-E1074	Fruehauf UXA-000002	2 1/2"	1 1/16"	1/4"

OUTER WASHER



PART No.	REPLACES	O.D.	I.D.	THICK
Z-E2833	Fruehauf UXA-000356-001	2 1/2"	1 5/16"	1/16"

## TORQUE ROD BUSHING

Polyurethane  
"TUFF-YELLO"



PART No.	REPLACES	FOR MODEL	O.D.	I.D.	O.A.L.
Z-PD1301 Euclid Z-E927	Hutchens 7620-00 Fruehauf UXA-000011	H-7600	2-3/16"	1-1/4"	2-3/8"

# FRUEHAUF

## FRUEHAUF EQUALIZER HARDWARE AND BUSHING ASSEMBLY

COMPRESSION WASHER



PART No.	REPLACES	O.D.	I.D.	THICK
Z-E1021	Fruehauf UXA-000003	4"	1 <sup>1</sup> / <sub>16</sub> "	<sup>1</sup> / <sub>4</sub> "

OUTER WASHER



PART No.	REPLACES	O.D.	I.D.	THICK
Z-E2832	Fruehauf UXA-000356-002	4"	2 <sup>1</sup> / <sub>2</sub> "	<sup>1</sup> / <sub>16</sub> "

## FRUEHAUF EQUALIZERS AND BUSHING ASSEMBLY

CAST EQUALIZER



Bushings Not Included

PART No.	REPLACES	APPLICATION
Z-E2830	Fruehauf UXA-000017	Early Model F-2 and Current Model F-3 Suspension. Use with E-1024 Equalizer Bushing Assembly.

EQUALIZER BOLT



PART No.	REPLACES	THREAD	O.A.L.
Z-E1019	Fruehauf UXA-00015-001	1"-14	10 <sup>9</sup> / <sub>16</sub> "

NUT



PART No.	REPLACES	THREAD	HEX	HIGH
Z-E937	Fruehauf FSP-006-02-PK9	1"-14	1 <sup>7</sup> / <sub>16</sub> "	<sup>7</sup> / <sub>8</sub> "

## EQUALIZER BUSHING

 Polyurethane "TUFF-YELLO"	PART No.	REPLACES	FOR MODEL	O.D.	I.D.	O.A.L.
	Z-PD1101 Euclid Z-E1020	Fruehauf UXA-000004	-		3 <sup>1</sup> / <sub>2</sub> "	2"

## EQUALIZER BUSHING

 <p>Rubber</p>	PART No.	REPLACES	FOR MODEL	O.D.	I.D.	O.A.L.
	Z-E1020	Fruehauf UXA-000004 Also common trailer draw bar bush	-	3 1/2"	2"	4 3/8"

## **POWERDOWN** "TUFF-YELLO" POLYURETHANE SUSPENSION BUSHES

FEATURES	BENEFITS
<ul style="list-style-type: none"> <li>• Made from high quality urethane elastomers</li> <li>• High capacity to bear tension and compression</li> <li>• Heavy load capacity and resistance to abrasion</li> <li>• Inherently oil resistant</li> <li>• Operate in temperature range of plus or minus 100 degrees Celsius</li> </ul>	<ul style="list-style-type: none"> <li>• Versatility and similar elasticity of rubber but with advantages of rigid plastic and metals</li> <li>• More durable than other bushes yet they retain their strength</li> <li>• Absorb friction without the aid of lubricant</li> <li>• Resists swelling and deterioration</li> <li>• Unaffected by normal operating temperatures</li> </ul>

# HUTCHENS

## AXLE ATTACHING PARTS

U-BOLT HI-NUT			
			
Heat Treated Thru Hardened Grade 8			
PART No.	REPLACES	FOR MODEL	DIMENSIONS
Z-E3002A	Hutchens 34-00	All	7/8" - 14 Thd. x 1 5/16" Hex x 1 5/32" High

TOP PLATE			
			
3" Wide 7 1/2" Long			
For Alternate "Solid" Version Use E-2873			
PART No.	REPLACES	FOR MODEL	APPLICATION
Z-E2907A	Hutchens 7029-00	All	For All Standard & No-Hop Axle Applications

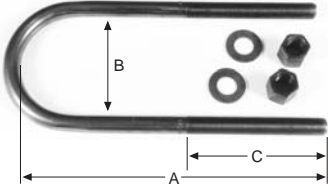
<b>ROUND U-BOLT ASSEMBLY</b> Includes Hi-Nuts and Washers 	PART No.	REPLACES HUTCHENS No.	THD.	A	B	C
	Z-EUB5161-14	7040-13 thru 7040-14	7/8" -14	14"	3"	4"
Z-EUB5165-18	7816-13 thru 7816-18	7/8" -14	18"	5"	6"	
Z-EUB5165-14	7816-05 thru 7816-14	7/8" -14	14"	5"	6"	

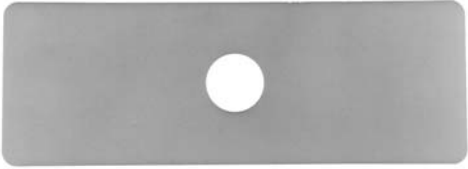
DELTRIN SPRING LINER		PART No.	REPLACES	FOR MODEL	APPLICATION
		Z-E2842	Hutchens 7052-02	All	For Single and Three Leaf Springs

## TORQUE ARM BOLTS & HARDWARE

TORQUE ARM BOLT			
			
PART No.	REPLACES	FOR MODEL	DIMENSIONS
Z-E2891	Hutchens 719-02	H-7700 CH-7800 CH-7700 H-9700 CH-9700	1" - 14 Thd. X 5" Long

FLANGED NUT			
			
PART No.	REPLACES	FOR MODEL	DIMENSIONS
Z-E2892	Hutchens 10562-00	H-7700 CH-7700 CH-7800 H-9700 CH-9700	1" 14 Thd. x 1 7/16" Hex x 7/8" High

# HUTCHENS

WASHER



PART No.	REPLACES	FOR MODEL	DIMENSIONS
Z-E1074	Hutchens 227-00	H-2200	2 1/2" O.D. 1 1/16" I.D. 1/4" Thick

TORQUE ARM NUT

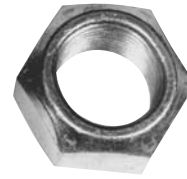

PART No.	REPLACES	FOR MODEL	DIMENSIONS
Z-E1835	Hutchens 34-02	H-7600 H-9600 CH-7600 CH-9600	7/8" - 14 Thd.

WASHER



PART No.	REPLACES	FOR MODEL	APPLICATION
Z-E2833	Hutchens 12710-01	H-7600 H-9600 CH-7600 CH-9600	2 1/2" O.D. 1 5/16" I.D. 1/16" Thick

## TORQUE ARM BUSHING

BUSHING



"TUFF-YELLO"

PART No.	REPLACES	DIMENSIONS
Z-PD1301 Euclid Z-E927	Hutchens 7620-00, H-9600, CH-9600, H-7600, CH-7600	2 3/16" Large O.D. 1 1/4" I.D. 2 3/8" Long

TORQUE ARM BUSHING - with Steel Insert



PART No.	REPLACES	FOR MODEL	DIMENSIONS
Z-E934	Hutchens 722-00	H-7700 CH-7700 CH-7800	1 29/32" O.D. 1" I.D. 3" Long

## EQUALIZER HARDWARE

TAB LOCK



PART No.	REPLACES	FOR MODEL	DIMENSIONS
Z-E2001	Hutchens 729-00	All	-

NUT





PART No.	REPLACES	FOR MODEL	DIMENSIONS
Z-E2002	Hutchens 37-03	All	5/8" - 18 Thd. x 15/16" Hex x 17/32" High

# HUTCHENS

EQUALIZER STEP BOLT	PART No.	REPLACES	FOR MODEL	THD	DIA.	LTH
	Z-E2000	Hutchens 7016-01	H-2200 H-7600 H-7700 CH-7600 CH-7700	5/8"-18	3/4"	6"

## EQUALIZERS AND BUSHINGS

EQUALIZER	PART No.	REPLACES	FOR MODEL
 <p data-bbox="647 869 799 913">Fabricated Steel Includes Z-E2003</p>	Z-E2781A	Hutchens 750-03	H-7600 H-7700

EQUALIZER BUSHING ASSEMBLY	PART No.	FOR MODEL	INCLUDES
	Z-E2003 (Rubber)	H-7600 H-7700 CH-7700 CH-7800	1 E1999A Bushing 2 Z-E2000 Bolt 1 Z-E2001 Tab Lock 2 Z-E2002 Nut

EQUALIZER SPRING ROLLER ASSEMBLY	PART No.	REPLACES	FOR MODEL
	Z-E4835		Both one and two bolt equalizers

# HUTCHENS

EQUALIZER BUSHING ONE BOLT



PART No.	REPLACES	FOR MODEL	O.D.	I.D.	LENGTH
Z-E7621 (Rubber)	Hutchens 16146-01	H-9600 H-9700 CH-9600 CH-9700	3 1/2"	1 1/8"	3 7/8"

EQUALIZER ONE BOLT



PART No.	REPLACES	APPLICATION & GENERAL INFORMATION
Z-E7532	Hutchens 16158-01	H-9700 with Z-E7621 Rubber Bushing

EQUALIZER ONE BOLT



PART No.	REPLACES	FOR MODEL	THREAD	LENGTH
Z-E7533	Hutchens 16150-01	H-9600 H-9700 CH-9600 CH-9700	1 1/8"-7	6 7/8"

LOCK NUT ONE BOLT EQUALIZER



PART No.	REPLACES	THREAD
Z-E4358	Hutchens 11154-00	1 1/8"-7 Thd.

# NAVISTAR INTERNATIONAL

EQUALIZER ASSEMBLY	PART No.	REPLACES	INCLUDES
	Z-E3783	Navistar 497790C2	1 E3784 Bushing 2 E4770 Roller Assembly

# REYCO

## REYCO SUSPENSION PARTS

### HEIGHT CONTROL VALVE

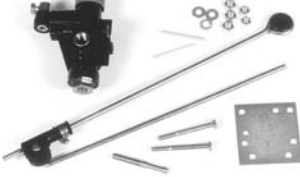

PART No.	REPLACES	FOR MODEL
Z-E8929A	Reyco 20108-02	102AR

### HI-NUT



Heat Treated  
Thru Hardened  
Grade 8

PART No.	REPLACES	THREAD	HEX	HIGH
Z-E3002A	Reyco 09352-01	7/8"-14	1 5/16"	1 5/32"

### ROUND U-BOLT ASSEMBLY

Includes Hi-Nuts and Washers

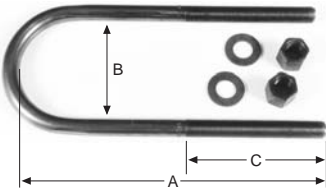

PART No.	REPLACES	THD.	A	B	C
Z-EUB5161-14	Reyco 08490-01 thru 08495-01	7/8"-14	14"	3"	6"
Z-EUB5165-14	Transpro 0102-10 thru 0102-14	7/8"-14	14"	5"	6"
Z-EUB5165-18	Transpro 0102-13 thru 0102-18	7/8"-14	18"	5"	6"

### DELRIN SPRING LINER

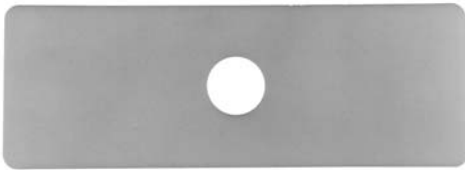

PART No.	REPLACES	DIMENSIONS
Z-E2842	Reyco T-5166 Transpro 0375-00	2 7/8" Wide x 8" Long x .043 Thick

### TOP PLATE

Inverted U-Bolt Mounting



PART No.	REPLACES	FOR MODEL
Z-E2907A	Reyco 0077-00	60" and 72" All Axles and Model 88

### TOP PLATE

Cast



PART No.	REPLACES	FOR MODEL
Z-E2873	Reyco 08677-01 08065-01 11808-01	All Models with Inverted U-Bolts

# REYCO

## HANGER & SPRING HARDWARE

BOLT		PART No.	REPLACES	FOR MODEL	THREAD	LENGTH
		Z-E2022	Reyco T-5549	101, 101A, 102	1/2"-20	5 1/2"
		Z-E1975	Reyco T-1703 T-5544	All Non-Transpro Models	1/2"-20	4 3/4"

EQUALIZER SPRING ROLLER ASSEMBLY		
		
PART No.	REPLACES	FOR MODEL
Z-E4835	Transpro 0741-00	Heavyweight and Super Heavy-Duty Model 88

SPRING ROLLER ASSEMBLY		
		
PART No.	FOR MODEL	INCLUDES
Z-E1975	All Non-Transpro Models	1 Z-E1972 Bolt 1 Z-E1971 Roller 1 Z-E5032 Nut 1 Z-E1974 Washer

## TORQUE ARM HARDWARE

TORQUE ARM NUT Hanger End					
					
PART No.	REPLACES	FOR MODEL	THREAD	HEX	HIGH
Z-E937	Reyco 14169-01 12327-01	21B	1"-14	1 7/16"	7/8"

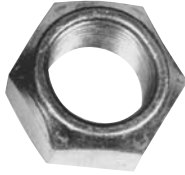
TORQUE ARM NUT					
					
PART No.	REPLACES	FOR MODEL	THREAD	HEX	HIGH
Z-E1835	Transpro 0002-09	Heavyweight and Super Heavy-Duty Model 88	7/8"-14	1 5/16"	3/4"

TORQUE ARM BOLT Axle Seat End		PART No.	REPLACES	FOR MODEL	THREAD	LENGTH
		Z-E901	Reyco 14181-01 10033-01	101, 181, 101F Axle Seat	7/8"-9	5 1/2"
		Z-E4833	Transpro 0001-08	Heavyweight and Super Heavy-Duty Model 88	7/8"-14	5 1/4"

WASHER		PART No.	REPLACES	FOR MODEL	O.D.	I.D.	THICK
		Z-E905	Reyco T-1724	101, 101A, 102	3 3/4"	1 1/16"	1/4"
Z-E905	Z-E907	Z-E907	Reyco T-2224	21B	2 3/4"	1 1/16"	3/16"

# REYCO

## TORQUE ARM BUSHINGS

TORQUE ARM BUSHING	PART No.	REPLACES	FOR MODEL	SMALL O.D.	LARGE O.D.	I.D.	LENGTH
	Z-E1160	Reyco T-5493	21B	1 13/16"	2 3/8"	1"	3"

TORQUE ARM BUSHING Axle Seat End	PART No.	REPLACES	FOR MODEL	SMALL O.D.	LARGE O.D.	I.D.	LENGTH
	Z-E1982	Reyco T-2242	102	1 3/4"	2 3/8"	1"	2 11/16"

Polyurethane "TUFF-YELLO"	PART No.	REPLACES	FOR MODEL	O.D.	I.D.	O.A.L.
	Z-PD1308 Euclid Z-E1980	Turner A-1712 Spicer L1032 Reyco 09729-01 Dayton 39400016 Navistar 347374C1 Transpro 0022-00	Q-Series 62 & 68 101A "Tri-lite" and early model navistar Heavyweight and super heavy-duty model 88	1-29/32"	7/8"	3"

## TORQUE ARM BUSHING ASSEMBLIES

	PART No.	REPLACES	FOR MODEL	INCLUDES
	Z-E9350	-	102 (Hanger End)	2 Bushing* 1 Z-E1166 Bolt 1 Z-E937 Nut 2 Z-E905 Washer  *Not sold separately

## EQUALIZER HARDWARE

EQUALIZER NUT						
PART No.	REPLACES	FOR MODEL	THREAD	HEX	HIGH	
Z-E2892	Transpro 0274-01	Heavyweight and Super Heavy-Duty Model 88	1"-14	1 7/16"	7/8"	

EQUALIZER SHAFT LOCK WASHER				
PART No.	REPLACES	FOR MODEL	I.D.	THICK
Z-E1969	Reyco 14246-01	101, 101A	1 1/2"	9/32"

# REYCO

**EQUALIZER SHAFT NUT**



PART No.	REPLACES	FOR MODEL	THREAD	APPLICATION
Z-E1968	Reyco 08687-01	101, 101A, 102	1 7/16"-12	Equalizer

**EQUALIZER WASHER**



PART No.	REPLACES	FOR MODEL	O.D.	I.D.	THICKNESS
Z-E1986A	Reyco 14249-01	21B	3 3/4"	1 1/16"	1/2"

**EQUALIZER SHAFT  
(Standard)**



PART No.	REPLACES	FOR MODEL	O.D.	LENGTH	THREAD
Z-E1967	Reyco 08686-01	101, 101A, 102	1 1/2"	8"	1 7/16"-12

**EQUALIZER SHAFT  
(Trailer)**



PART No.	REPLACES	FOR MODEL	O.D.	LENGTH	NOTE
Z-E3972	Reyco 14247-01	21B	1 5/8"	8 11/16"	1"-8 Bolt Holes at Both Ends

**EQUALIZER BOLT**



PART No.	REPLACES	FOR MODEL	LENGTH	THREAD
Z-E4830	Transpro	Heavyweight and Super Heavy-Duty Model 88	6 7/16"	1"-14

**EQUALIZER SHAFT LOCK SCREW**



PART No.	REPLACES	FOR MODEL	THREAD	LENGTH
Z-E1987	Reyco 14248-01	21B	1"-8	2 1/2"

## EQUALIZER BUSHINGS

**EQUALIZER BUSHING**  
(Standard) New Style



PART No.	REPLACES	FOR MODEL	O.D.	I.D.	LENGTH
Z-E3977	Reyco 14713-01	-	3 1/8"	1 1/2"	4 1/2"

**EQUALIZER BUSHING**



PART No.	REPLACES	FOR MODEL	O.D.	I.D.	LENGTH
Z-E1072	Reyco T-3214	30, 31, 41, 42, 21B, 72" Widespread	3 1/8"	2"	4 1/4"

**EQUALIZER BUSHING**  
(Trailer)



PART No.	REPLACES	FOR MODEL	O.D.	I.D.	LENGTH
Z-E1159	Reyco T-5524	21B	3 3/8"	1 5/8"	4 13/32"

**EQUALIZER BUSHING**



PART No.	REPLACES	FOR MODEL	O.D.	I.D.	LENGTH
Z-E4827	Transpro 0649-02	Super Heavy-Duty Model 86 & 88	3 5/16"	1 1/32"	4"

## EQUALIZERS

**EQUALIZER - CAST**



Bushings not included

PART No.	REPLACES	O.A.L.	FOR MODEL
Z-E2846A	Reyco T-5427	18"	21B

**EQUALIZER - FABRICATED**



Includes Z-E4827 Bush

PART No.	REPLACES	FOR MODEL	O.A.L.	BUSHING HOLE DIA.
Z-E4813	Transpro 0650-00 0758-00 0058-00	Super Heavy-Duty Model 88	16 1/2"	3 1/4"

# ROCKWELL

## BRAKE REPAIR KITS

### ROCKWELL 16 1/2" "P" SERIES AND STD. FORGE EARLY MODEL BRAKE

APPLICATION INFORMATION		KIT NUMBER
		<p><b>EUCLID KIT Z-KIT45HD</b></p> <p>Includes:</p> <ul style="list-style-type: none"> <li>2 Z-E512S Anchor Pin*</li> <li>2 Z-E2177 Knurled Roller</li> <li>1 Z-E1880S Heavy Duty Return Spring*</li> <li>2 Z-E539 Roller Retainer</li> <li>4 Z-E801 Lock Ring</li> <li>2 Z-E579A Lock Screw</li> <li>4 Z-E1269 Seal</li> <li>2 Z-E747 Spring Retainer</li> </ul> <p><i>*Not sold separately</i></p>

### "UNIVERSAL" KIT WITH "FREE-FLOATING" ANCHOR PIN USED ON 16 1/2" EATON, FRUEHAUF, ROCKWELL, SPICER (DANA) AND STD. FORGE BRAKES

APPLICATION INFORMATION		KIT NUMBER
<p>All 16 1/2" P brakes on truck, tractor and trailer axles with fab shoes. Contains phosphate coated anchor pins. Services one brake</p>		<p><b>EUCLID KIT Z-R509000</b></p> <p>Includes:</p> <ul style="list-style-type: none"> <li>2 Z-1259M1131 Anchor Pin</li> <li>1 Z-2258P354 Return Spring</li> <li>2 Z-1779R18 Roller</li> <li>2 Z-1225B496 Anchor Pin Bushing</li> <li>2 Z-1218G85 Return Spring Pin</li> <li>2 Z-1718Y103 Roller Retainer</li> <li>4 Z-1229D2942 Snap Ring</li> <li>4 Z-1229B1848 Anchor Pin Washer</li> </ul>

### ROCKWELL 16 1/2" "Q", "Q PLUS" AND SPICER (DANA) "FAST CHANGE" BRAKE

APPLICATION INFORMATION		KIT NUMBER
<p>Services all Q brake sizes, including Fruehauf, except those on front steering axles. Services one brake.</p>		<p><b>EUCLID KIT Z-KIT8000</b></p> <p>Includes:</p> <ul style="list-style-type: none"> <li>2 Z-1259N274 Anchor Pin</li> <li>1 Z-2258U619 Return Spring</li> <li>2 Z-2258Q615 Retainer Spring</li> <li>2 Z-1779R18 Roller</li> <li>2 Z-1225B496 Anchor Pin Bushing</li> <li>2 Z-1218G85 Return Spring Pin</li> <li>2 Z-3105B210 Roller Retainer</li> </ul>

APPLICATION INFORMATION		KIT NUMBER
<p>Services all Q brake sizes, including Fruehauf, except those on front steering axles. Services one brake.</p>		<p><b>EUCLID KIT Z-KIT8002SS</b></p> <p>Includes:</p> <ul style="list-style-type: none"> <li>1 Z-2258U619 Return Spring</li> <li>2 Z-2258Q615 Retainer Spring</li> </ul>

# ROCKWELL

## BRAKE SHOE ROLLERS

"Hi-Kromite Plated"

"POSI-ROLL" DIAMOND KNURLED BRAKE SHOE ROLLERS For Fabricated Brake Shoes	PART No.	REPLACES	O.A. LENGTH	LENGTH OF LARGE DIA.	OD	APPLICATION & GENERAL INFORMATION
		Z-E2177	Rockwell 1779R18 Diamond T 26282 Fruehauf 330733 GM 2295551 Spicer M16WJ104 Std. Forge 204101-001 Trailmobile 7-23-7 WhiteGMC 827702	2 <sup>7</sup> / <sub>32</sub> "	1 <sup>9</sup> / <sub>32</sub> "	1 <sup>1</sup> / <sub>4</sub> "

## BRAKE SHOE ANCHOR PINS

HARD CHROME PLATED	PART No.	REPLACES	LENGTH	OD	APPLICATION & GENERAL INFORMATION
	Z-E512BK	Rockwell 1259-Q-251 Fruehauf 330673 GM 2295423 Kershaw 11093 Mack 3015M-86 Navistar 126403R1 Spicer M10WJ162 Std. Forge 203102-001	2 <sup>7</sup> / <sub>8</sub> "	1 <sup>1</sup> / <sub>4</sub> "	For Rockwell & Fruehauf Fabricated Shoes

HARD CHROME PLATED	PART No.	REPLACES	LENGTH	OD	APPLICATION & GENERAL INFORMATION
	Z-E609	Rockwell 1259-N-170 Fruehauf 578322 Spicer M10WJ164 Std. Forge 203106	2 <sup>15</sup> / <sub>32</sub> "	1 <sup>1</sup> / <sub>4</sub> "	For Rockwell & Fruehauf "Pro-Par" axle with Fabricated Shoes

## BRAKE SHOE RETURN SPRINGS

For 16<sup>1</sup>/<sub>2</sub>" Brakes

HEAVY-DUTY	PART No.	REPLACES	O.A. LENGTH	O.D.	APPLICATION & GENERAL INFORMATION
 100 lb. MEGA PLUS SPRING	Z-E1880B	Rockwell 2258-Z-416	8"	1 <sup>1</sup> / <sub>4</sub> "	Use for Spicer "XL" Brakes and Rockwell "P" Brakes.

## CAM BRAKE SHOES

For 16<sup>1</sup>/<sub>2</sub>" "P" Brakes

UNLINED SHOE No.	REPLACES	SIZE	FMSI No.	RIVET
	Z-E2241 Rockwell A-3222-R-876 A-3722-N-66	16 <sup>1</sup> / <sub>2</sub> " x 7"	4515E	10-8

For 16<sup>1</sup>/<sub>2</sub>" "Q" Brakes

UNLINED SHOE No.	REPLACES	SIZE	FMSI No.	RIVET
	Z-A3222S1293 Rockwell A3222S1293	16 <sup>1</sup> / <sub>2</sub> " x 7"	4515G	RV-3109 1/4"

# ROCKWELL

## DUST SHIELDS FOR MULTI-PURPOSE TRAILER APPLICATIONS

	PART No.	BRAKE SIZE	REPLACES
	Z-E886 STEEL	16 1/2" x 6" 16 1/2" x 7"	Eaton B-1688A Fruehauf 966691LH 966692RH Rockwell 3236-A-1249LH 3236-B-1250RH A1-3236-A-1249 Spicer M16WB101 Std. Forge UB1172, UB1165 & 5102

## BRAKE CAMSHAFTS

### 1 1/2" DIAMETER MULTI-APPLICATION CAMSHAFTS FOR TRAILERS WITH 16 1/2" BRAKES - Double Groove

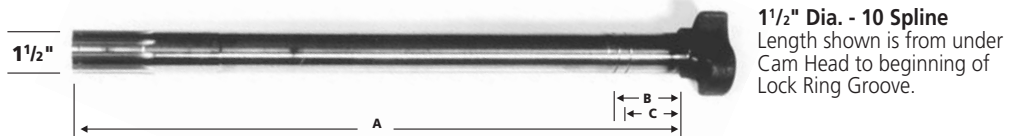

1 1/2" Dia. - 10 Spline  
Length shown is from under  
Cam Head to beginning of  
Lock Ring Groove.

PART No.	REPLACES	A	B	C	APPLICATION & GENERAL INFORMATION
Z-E1425 LH	Rockwell 2210-N-2484 & 2210-G-3595 Fruehauf 219316 & 580443 Spicer M16WK103-17 Std. Forge 202100-205L Trailmobile 7-5-64L	20 3/8"	2 7/32"	1 5/8"	"Standard" Universal  1 5/8" Groove used on Paymaster RN & RL Axles
Z-E1424 RH	Rockwell 2210-M-2483 & 2210-F-3594 Fruehauf 219317 & 580444 Spicer M16WK102-17 Std. Forge 202100-205R Trailmobile 7-5-64R				

### FOR ROCKWELL DRIVE AXLES WITH 16 1/2" STANDARD BRAKES

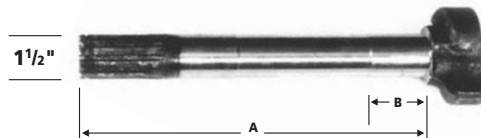

1 1/2" Dia. - 10 Spline  
Length shown is from under  
Cam Head to beginning of  
Lock Ring Groove.

PART No.	REPLACES	A	B	APPLICATION & GENERAL INFORMATION
Z-E2479 LH	Rockwell 2210-X-5640S 2210-Y-2443	8 1/2"	1 3/4"	For Mack Trucks using Rockwell 38,000 and 44,000 lb. axles.
Z-E2478B RH	Rockwell 2210-W-5639S 2210-X-2442			
Z-E1774C LH	Rockwell 2210-L-3028 2210-X-5354S	11 1/4"	1 3/4"	-
Z-E1773C RH	Rockwell 2210-K-3027 2210-W-5353S			

# ROCKWELL

## CAMSHAFT REPAIR KITS For 16<sup>1</sup>/<sub>2</sub>" Dia. Cam Brakes

APPLICATION		KIT NUMBER
Drive axle P and Q brakes		<b>EUCLID KIT Z-E2086B</b>  Includes: 4 Z-E5512 Bushing 4 Z-E654 Seal 2 Z-E656 "D" Washer 2 Z-E580 Washer 2 Z-E581 Washer 2 Z-E526 Lock Ring 2 Z-E3859 Gasket 2 Z-E4736 Lock Ring

APPLICATION		KIT NUMBER
Trailer axle P and Q brakes		<b>EUCLID KIT Z-E1357A</b>  Includes: 2 Z-E943 Bushing 2 Z-E535 Bushing 4 Z-E580 Washer 2 Z-E581 Washer 2 Z-E656 "D" Washer 4 Z-E526 Lock Ring 2 Z-E4736 Lock Ring

APPLICATION		KIT NUMBER
FOR LATE MODEL ROCKWELL 4000-6000 SERIES TRAILER AXLES  With 1 <sup>5</sup> / <sub>8</sub> " Dia. Camshafts  Also used for 12 <sup>1</sup> / <sub>4</sub> " "Q" Brakes  Z-E3520AHD Replaces Rockwell KIT 8048  Contains Lock Rings for Camshafts with narrow or wide grooves.		<b>EUCLID KIT Z-E3520AHD</b>  Includes: 2 Z-E564 Washer 2 Z-E1318AHD Support Assembly 2 Z-E801 Lock Ring 2 Z-E2405 Seal 2 Z-E2406 Seal 2 Z-E2407 Outer Bushing 2 Z-E2408 Inner Bushing 2 Z-E1569 Lock Ring 2 Z-E1113 Washer 4 Z-E2411A Washer 2 Z-E5093 Lock Ring

## CAMSHAFT SUPPORT BUSHING ASSEMBLY FOR ROCKWELL TRAILER AXLES

	PART No.	REPLACES	APPLICATION
	Z-E1318A	Rockwell A-3105-V-282	Original OEM style Bushing Assembly

# ROCKWELL

## CAMSHAFT BUSHINGS

NYLON				
				
PART No.	O.D.	I.D.	LENGTH	REPLACES
Z-E2361	2 1/8"	1 1/2"	1"	Rockwell 1225-R-1058 NOTE: For use in Z-E1318A Assembly only. Do not use in Z-E1318AHD. Use Z-E1314 O-Ring on each side.

NYLON				
				
PART No.	O.D.	I.D.	LENGTH	REPLACES
Z-E535	2 3/4"	1 1/2"	2 1/2"	Rockwell A-3299-G-1541

### FOR EARLY MODEL ROCKWELL 500 SERIES AXLES

		DESCRIPTION	PART No.	REPLACES	I.D.	APPLICATION
YELLOW	WHITE	SPLIT BUSHING - SOLD ONLY AS A SET	Z-E943	Rockwell A-1225-D-420 A-1225-V-438	1 1/2"	YELLOW half is used on inboard side of spider  WHITE half is used on outboard side of spider

## CAMSHAFT SPACER WASHERS

	PART No.	REPLACES	O.D.	I.D.	THICK	PLATED	APPLICATION
	Z-E581	Rockwell 1229-Q-771 Fruehauf 219292 Trailmobile 7-9-11	2 1/4"	1 17/32"	.032	YES	Used on all 1 1/2" dia. Camshafts
	Z-E580	Rockwell 1229-R-122 Fruehauf 219293 Eaton AXA-0432-1 B-1216 & 820009	2 1/4"	1 17/32"	.060	YES	Use on all 1 1/2" dia. Camshafts Including End Washer for Fruehauf "Pro-Par" Camshaft
	Z-E1113	Rockwell 1229-B-1848	1 7/8"	1 17/64"	.060	YES	For Rockwell 4000-6000 Series Axle Spline End

## CAMSHAFT LOCK RINGS

	PART No.	REPLACES	I.D.	THICK	APPLICATION
	Z-E526	Rockwell 1229-Z-1118 Fruehauf 219160 Eaton B-1716 & 820095 GM 2101124	1 31/64"	1/16"	For all 1 1/2" dia. Camshafts

# ROCKWELL

## CAMSHAFT SEALS

	PART No.	REPLACES	O.D.	I.D.	THICK	APPLICATION
	Z-E1416	Rockwell Spicer Std. Forge 1205-M-1105 M16HH100 408101	1 <sup>7</sup> / <sub>8</sub> "	1 <sup>1</sup> / <sub>2</sub> "	<sup>3</sup> / <sub>16</sub> "	For 1 <sup>1</sup> / <sub>2</sub> " dia. Camshafts. Use with late model Rockwell and Std. Forge Weld-on Spiders.
	Z-E1416A	Eaton 40864 79903	1 <sup>7</sup> / <sub>8</sub> "	1 <sup>1</sup> / <sub>2</sub> "	<sup>1</sup> / <sub>4</sub> "	Same as E-1416 except <sup>1</sup> / <sub>4</sub> " thick. Cannot be used on late model Rockwell Axles.

## MANUAL SLACK ADJUSTERS

	PART No.	REPLACES	FITS CAM SPLINE	ARM LENGTH	MAX. TORQUE RATING
	Z-E2458BK	Bendix 286965 Eagle A-7085 Midland KN44051 Rockwell R822003 Sloan 2011, 2031, 2096	1 <sup>1</sup> / <sub>2</sub> " - 28	5" - 6" - 7"	26,000 lbs.

## TRAILER AXLE SPINDLE NUTS

ROCKWELL RL, RN, RQ, TK, TKL, TKN AXLES - "POSITIVE" ADJUSTMENT



INNER NUT



OUTER NUT



LOCK WASHER



TAB LOCK

DESCRIPTION	PART No.	REPLACES	ACROSS FLATS	THREAD SIZE	THICKNESS	O.D.	I.D.
POSITIVE ADJUST INNER NUT	Z-E1253	Rockwell 1227-B-678	3 <sup>13</sup> / <sub>16</sub> "	2 <sup>3</sup> / <sub>8</sub> " - 16	<sup>1</sup> / <sub>2</sub> "	-	-
OUTER NUT	Z-E1251	Rockwell 1227-Z-676	3 <sup>1</sup> / <sub>4</sub> "	2 <sup>3</sup> / <sub>8</sub> " - 16		-	-
LOCK WASHER	Z-E1252	Rockwell 1229-T-1996	-	-	<sup>3</sup> / <sub>8</sub> "	3 <sup>13</sup> / <sub>16</sub> "	2 <sup>13</sup> / <sub>32</sub> "
TAB LOCK	Z-E3010	Used w/ Positive Adjust Nut or Replacement Service Nut to Lock Outer Nut in Place	-	-	.060	4"	2 <sup>13</sup> / <sub>32</sub> "
*REPLACEMENT SERVICE NUT	Z-E2128	Rockwell A-1227-S-877	3 <sup>13</sup> / <sub>16</sub> "	2 <sup>3</sup> / <sub>8</sub> " - 16	<sup>1</sup> / <sub>2</sub> "	-	-

\* Used in place of Z-E1253 to convert to "manual" adjustment.

# ROCKWELL

## ROCKWELL, EATON, KERSHAW, & STD. FORGE 17,000 & 18,000 LB. TRADE AXLES



INNER NUT



OUTER NUT



LOCK WASHER



TAB LOCK

DESCRIPTION	PART No.	REPLACES	ACROSS FLATS	THREAD SIZE	THICKNESS	O.D.	I.D.
INNER NUT	Z-E540	Eaton 820394 Spicer M10HN101 Std. Forge 103103-002 Rockwell 1227-C-549	3 <sup>13</sup> / <sub>16</sub> "	2 <sup>5</sup> / <sub>8</sub> " -16	3/8"	-	-
OUTER NUT	Z-E572	Eaton 820395 Spicer M10HN102 Std. Forge 103102-001 Rockwell 1227-B-756	3 <sup>1</sup> / <sub>4</sub> "	2 <sup>5</sup> / <sub>8</sub> " -16	3/8"	-	-
LOCK WASHER	Z-E573	Eaton 820396 Spicer M10HN100 Std. Forge 105107 Rockwell 1229-V-1660	NOTE: Used With All Standard Depth Axle Keyway (long hub)		1/4"	3 <sup>15</sup> / <sub>16</sub> "	2 <sup>41</sup> / <sub>64</sub> "
TAB LOCK	Z-E2237	Std. Forge 105106	A = 5/32" long		.060	4 <sup>1</sup> / <sub>32</sub> "	2 <sup>41</sup> / <sub>64</sub> "

## ROCKWELL, SPICER, & STD. FORGE 11,000 LB. AXLES



DESCRIPTION	PART No.	REPLACES	ACROSS FLATS	THREAD SIZE	THICKNESS	O.D.	I.D.
LOCK WASHER	Z-E1000	Rockwell 1229-T-462 Spicer M10HN130 Std. Forge 105109	-	-	.062	2 <sup>7</sup> / <sub>8</sub> "	1 <sup>1</sup> / <sub>2</sub> " x 1 <sup>3</sup> / <sub>8</sub> " D Hole

# ROCKWELL

## STEERING AXLE SPINDLE NUTS

ROCKWELL FD-900, FD-901, FE-900, FF-901, FF-931 AXLES



DESCRIPTION	PART No.	REPLACES	ACROSS FLATS	THREAD SIZE	THICKNESS	O.D.	I.D.
WASHER	Z-E2298	Rockwell 1229-F-474	-	-	1/32"	3"	1 17/32"

## DRIVE AXLE SPINDLE NUTS

ROCKWELL "F" SERIES AXLES



INNER NUT



OUTER NUT

DESCRIPTION	PART No.	REPLACES	ACROSS FLATS	THREAD SIZE	THICKNESS	O.D.	I.D.
INNER NUT	Z-E2417	Rockwell 1227-U-515	3 1/2"	2 1/2" -16	5/16"	-	-
OUTER NUT	Z-E2419	Rockwell 1227-D-446	3 1/2"	2 1/2" -16	5/16"	-	-

## BRAKE REPAIR KITS

### SPICER (DANA) 12<sup>1</sup>/<sub>4</sub>" NEW STYLE "U" BRAKE

APPLICATION		KIT NUMBER
<p>For use with Old Style "Fast-Rise" Camshafts only.</p>		<p><b>EUCLID KIT Z-E3782</b></p> <p>Includes:</p> <ul style="list-style-type: none"> <li>2 Z-E5304 Hard Chrome Anchor Pin</li> <li>2 Z-E586 Knurled Roller</li> <li>2 Z-E539 Roller Retainer</li> <li>1 Z-E2398 Return Spring</li> <li>2 Z-E747 Spring Retainer</li> <li>1 Z-E5305 Retainer Clip</li> </ul>

### SPICER (DANA) 12<sup>1</sup>/<sub>4</sub>" OLD STYLE "U" BRAKE

APPLICATION		KIT NUMBER
		<p><b>EUCLID KIT Z-E5306</b></p> <p>Includes:</p> <ul style="list-style-type: none"> <li>2 Z-E5304 Hard Chrome Anchor Pin</li> <li>2 Z-E2395 Knurled Roller</li> <li>2 Z-E2396 Roller Pin</li> <li>1 Z-E2398 Return Spring</li> <li>2 Z-E2399 Spring Retainer</li> <li>2 Z-E527 Lock Ring</li> <li>1 Z-E5305 Retainer Clip</li> </ul>

### STD FORGE 12<sup>1</sup>/<sub>4</sub>" BRAKE WITH FABRICATED SHOES

APPLICATION		KIT NUMBER
<p>Replaces Spicer (Dana) M12LK101X</p>		<p><b>EUCLID KIT Z-E2402HD</b></p> <p>Includes:</p> <ul style="list-style-type: none"> <li>2 Z-E2390 Hard Chrome Anchor Pin</li> <li>4 Z-E2391 Washer</li> <li>4 Z-E2392 Lock Ring</li> <li>2 Z-E2395 Knurled Roller</li> <li>2 Z-E2396 Roller Pin</li> <li>2 Z-E527 Lock Ring</li> <li>1 Z-E2398 Return Spring</li> <li>2 Z-E2399 Spring Retainer</li> <li>2 Z-E2389 Stainless Steel Anchor Pin Bushing</li> </ul>

### "UNIVERSAL" KIT WITH "FREE-FLOATING" ANCHOR PIN USED ON 16<sup>1</sup>/<sub>2</sub>" EATON, FRUEHAUF, ROCKWELL, SPICER (DANA) AND STD. FORGE BRAKES

APPLICATION INFORMATION		KIT NUMBER
<p>All 16<sup>1</sup>/<sub>2</sub>" P brakes on truck, tractor and trailer axles with fab shoes. Contains phosphate coated anchor pins. Services one brake</p>		<p><b>EUCLID KIT Z-R509000</b></p> <p>Includes:</p> <ul style="list-style-type: none"> <li>2 Z-1259M1131 Anchor Pin</li> <li>1 Z-2258P354 Return Spring</li> <li>2 Z-1779R18 Roller</li> <li>2 Z-1225B496 Anchor Pin Bushing</li> <li>2 Z-1218G85 Return Spring Pin</li> <li>2 Z-1718Y103 Roller Retainer</li> <li>4 Z-1229D2942 Snap Ring</li> <li>4 Z-1229B1848 Anchor Pin Washer</li> </ul>

# SPICER / STD FORGE / INGERSOL

## ROCKWELL 16<sup>1</sup>/<sub>2</sub>" "Q", "Q PLUS" AND SPICER (DANA) "FAST CHANGE" BRAKE

APPLICATION INFORMATION		KIT NUMBER
Services all Q brake sizes, incl. Fruehauf, exc. those on front steering axles. Services one brake.		<b>EUCLID KIT Z-KIT8000</b>  Includes: 2 Z-1259N274 Anchor Pin 1 Z-2258U619 Return Spring 2 Z-2258Q615 Retainer Spring 2 Z-1779R18 Roller 2 Z-1225B496 Anchor Pin Bushing 2 Z-1218G85 Return Spring Pin 2 Z-3105B210 Roller Retainer

## BRAKE SHOE ROLLERS "Hi-Kromite Plated"

<b>"POSI-ROLL" DIAMOND KNURLED BRAKE SHOE ROLLERS</b> For Fabricated Brake Shoes  	PART No.	REPLACES	O.A. LENGTH	LENGTH OF LARGE DIA.	O.D.	APPLICATION & GENERAL INFORMATION
	Z-E2177	Rockwell 1779R18 Diamond T 26282 Fruehauf 330733 GM 2295551 Spicer M16WJ104 Std. Forge 204101-001 Trailmobile 7-23-7 WhiteGMC 827702	2 <sup>7</sup> / <sub>32</sub> "	1 <sup>9</sup> / <sub>32</sub> "	1 <sup>1</sup> / <sub>4</sub> "	For 16 <sup>1</sup> / <sub>2</sub> " Brakes with Fabricated Brake Shoes

## BRAKE SHOE ANCHOR PINS

<b>HARD CHROME PLATED</b>  	PART No.	REPLACES	LENGTH	O.D.	APPLICATION & GENERAL INFORMATION
	Z-E512BK	Rockwell 1259-Q-251 Fruehauf 330673 GM 2295423 Kershaw 11093 Mack 3015M-86 Navistar 126403R1 Spicer M10WJ162 Std. Forge 203102-001	2 <sup>7</sup> / <sub>8</sub> "	1 <sup>1</sup> / <sub>4</sub> "	For Rockwell & Fruehauf Fabricated Shoes

<b>HARD CHROME PLATED</b>  	PART No.	REPLACES	LENGTH	O.D.	APPLICATION & GENERAL INFORMATION
	Z-E609	Rockwell 1259-N-170 Fruehauf 578322 Spicer M10WJ164 Std. Forge 203106	2 <sup>15</sup> / <sub>32</sub> "	1 <sup>1</sup> / <sub>4</sub> "	For Rockwell & Fruehauf "Pro-Par" axle with Fabricated Shoes

## BRAKE SHOE RETURN SPRINGS

<b>FOR 16<sup>1</sup>/<sub>2</sub>" BRAKES</b>    HEAVY-DUTY 100 lb. MEGA PLUS SPRING	PART No.	REPLACES	O.A. LGTH	O.D.	APPLICATION & GENERAL INFORMATION
	Z-E1880B RED	Rockwell 2258-Z-416	8"	1 <sup>1</sup> / <sub>4</sub> "	Heavy-Duty version Use for Spicer "XL" Brakes and Rockwell "P" Brakes

# SPICER / STD FORGE / INGERSOL

## CAM BRAKE SHOES - 12 1/4" DIA. BRAKES

**STANDARD FORGE**  
Heavy-Duty Version for Severe Service



PART No.	REPLACES	SIZE	FMSI No.	RIVET
Z-E2394	Spicer M12WS127 Std. Forge 201140	12 1/4" x 7 1/2"	4591	20-8

**SPICER & STANDARD FORGE**  
"U" BRAKE



PART No.	REPLACES	SIZE	FMSI No.	RIVET
Z-E5303A	Spicer M12WS149X Spicer (Old) M12WS129X Std. Forge 204102	12 1/4" x 7 1/2"	4692	10-8

## DUST SHIELDS FOR MULTI-PURPOSE TRAILER APPLICATIONS



BRAKE SIZE	PART No.	REPLACES
16 1/2" x 6" 16 1/2" x 7"	Z-E886 STEEL	Eaton B-1688A Fruehauf 966691LH 966692RH Rockwell 3236-A-1249LH 3236-B-1250RH A1-3236-A-1249 Spicer M16WB101 Std. Forge UB1172, UB1165 & 5102

## BRAKE CAMSHAFTS FOR SPICER (STD. FORGE) TRAILER AXLES WITH 12 1/4" BRAKES

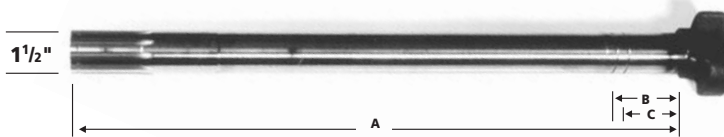

**1 1/2" Dia. - 10 Spline**  
Length shown is from under  
Cam Head to beginning of  
Lock Ring Groove.

PART No.	REPLACES	A	B	C	APPLICATION & GENERAL INFORMATION
Z-E1411 LH	Std. Forge 202103-213LH, UB22-64L Spicer M12WK107-6	21 1/8"	2 7/32"	2 21/32"	Spicer (Dana) & Std. Forge 12 1/4" x 5 1/2" & 12 1/4" x 7 1/2" Brakes
Z-E1410 RH	Std. Forge 202103-213RH, UB22-64R Spicer M12WK106-6				
Z-E1423 LH	Std. Forge 202103-233LH, UB24-15L Spicer M12WK101-17	23 1/4"	2 7/32"	2 21/32"	
Z-E1422 RH	Std. Forge 202103-233RH, UB24-15R Spicer M12WK100-17				

## BRAKE CAMSHAFTS

**1 1/2" DIAMETER MULTI-APPLICATION CAMSHAFTS FOR TRAILERS  
WITH 16 1/2" BRAKES - Double Groove**

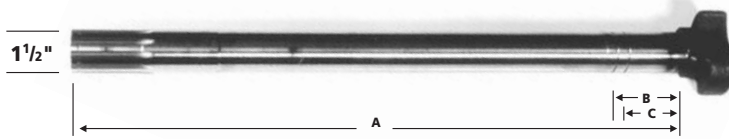

**1 1/2" Dia. - 10 Spline**  
Length shown is from under  
Cam Head to beginning of  
Lock Ring Groove.

PART No.	REPLACES	A	B	C	APPLICATION & GENERAL INFORMATION
Z-E1425 LH	Rockwell Fruehauf Spicer Std. Forge Trailmobile 2210-N-2484 & 2210-G-3595 219316 & 580443 M16WK103-17 202100-205L 7-5-64L	20 <sup>3</sup> / <sub>8</sub> "	2 <sup>7</sup> / <sub>32</sub> "	1 <sup>5</sup> / <sub>8</sub> "	"Standard" Universal  1 <sup>5</sup> / <sub>8</sub> " Groove used on Paymaster RN & RL Axles
Z-E1424 RH	Rockwell Fruehauf Spicer Std. Forge Trailmobile 2210-M-2483 & 2210-F-3594 219317 & 580444 M16WK102-17 202100-205R 7-5-64R				
Z-E1095 LH	Eaton Std. Forge Spicer F-1691-25 202100-236L M16WK103-25	23 <sup>7</sup> / <sub>16</sub> "	2 <sup>5</sup> / <sub>16</sub> "	2 <sup>7</sup> / <sub>32</sub> "	Extra long for use with Air Ride Suspensions  Extra length keeps slack adjuster from rubbing on air bags and causing premature rupture
Z-E1094 RH	Eaton Std. Forge Spicer B-1691-26 202100-236R M16WK102-25				

## CAMSHAFT REPAIR KITS FOR 12 1/4" DIA. BRAKES

APPLICATION		KIT NUMBER
<p>For late model Spicer &amp; Standard Forge Axles</p> <p>Replaces Spicer M12KY101</p>		<p><b>EUCLID KIT Z-E2469</b></p> <p>Includes:</p> <ul style="list-style-type: none"> <li>2 Z-E580 Washer</li> <li>2 Z-E581 Washer</li> <li>4 Z-E1416A Seal</li> <li>2 Z-E2404 Washer</li> <li>4 Z-E526 Lock Ring</li> <li>2 Z-E759 Bushing</li> <li>2 Z-E2102 Bushing</li> <li>2 Z-E2409 Washer</li> </ul>

## FOR 16 1/2" DIA. CAM BRAKES

APPLICATION		KIT NUMBER
<p>For Spicer &amp; Standard Forge late model A-17S, A-19SA22-S Axles</p> <p>With Weld-on Spiders</p> <p>Replaces Spicer M16KY20</p>		<p><b>EUCLID KIT Z-E2287</b></p> <p>Includes:</p> <ul style="list-style-type: none"> <li>4 Z-E1416A Seal</li> <li>2 Z-E719 Washer</li> <li>2 Z-E759 Bushing</li> <li>2 Z-E2102 Bushing</li> <li>4 Z-E526 Lock Ring</li> <li>2 Z-E2409 Washer</li> <li>2 Z-E580 Washer</li> <li>2 Z-E5093 Lock Ring</li> <li>2 Z-E801 Lock Ring</li> <li>4 Z-E1113 Washer</li> </ul>

## CAMSHAFT BUSHINGS

**NYLON**



PART No.	O.D.	I.D.	LENGTH
<b>Z-E759</b>	1 7/8"	1 1/2"	1 1/2"
	Replaces: Spicer M10WJ118 Std. Forge 405129		

**MOLYBDENUM**



PART No.	O.D.	I.D.	LENGTH
<b>Z-E1365</b>	1 7/8"	1 1/2"	1 1/2"
	Molybdenum Disulfide Version of E-759 & E-807 For On-Highway Use Only		

**NYLON**



PART No.	O.D.	I.D.	LENGTH
<b>Z-E2102</b>	2 15/32"	1 1/2"	1 3/4"
	Replaces: Spicer M10WJ107 Std. Forge 405128		

## TRAILER AXLE SPINDLE NUTS

ROCKWELL, EATON, KERSHAW, & STD. FORGE 17,000 & 18,000 LB. TRADE AXLES



INNER NUT



OUTER NUT



LOCK WASHER

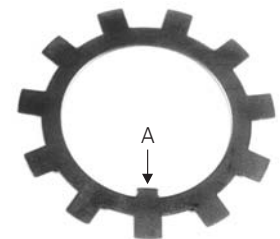

TAB LOCK

DESCRIPTION	PART No.	REPLACES	ACROSS FLATS	THREAD SIZE	THICKNESS	O.D.	I.D.
INNER NUT	<b>Z-E540</b>	Eaton 820394 Spicer M10HN101 Std. Forge 103103-002 Rockwell 1227-C-549	3 13/16"	2 5/8" -16	3/8"	-	-
OUTER NUT	<b>Z-E572</b>	Eaton 820395 Spicer M10HN102 Std. Forge 103102-001 Rockwell 1227-B-756	3 1/4"	2 5/8" -16	3/8"	-	-
LOCK WASHER	<b>Z-E573</b>	Eaton 820396 Spicer M10HN100 Std. Forge 105107 Rockwell 1229-V-1660	NOTE: Used With All Standard Depth Axle Keyway (long hub)		1/4"	3 15/16"	2 41/64"
TAB LOCK	<b>Z-E2237</b>	Std. Forge 105106	A = 5/32" long		.060	4 1/32"	2 41/64"

# SPICER / STD FORGE / INGERSOL

## ROCKWELL, SPICER & STD. FORGE 11,000 LB. AXLES



DESCRIPTION	PART No.	REPLACES	ACROSS FLATS	THREAD SIZE	THICKNESS	O.D.	I.D.
LOCK WASHER	Z-E1000	Rockwell 1229-T-462 Spicer M10HN130 Std. Forge 105109	-	-	.062	2 <sup>7</sup> / <sub>8</sub> "	1 <sup>1</sup> / <sub>2</sub> " x 1 <sup>3</sup> / <sub>8</sub> " D Hole

## TRAILER AXLE SPINDLE NUTS SPICER D21 & D22, & STD. FORGE A25 & A26 AXLES



INNER NUT



OUTER NUT



LOCK WASHER



TAB LOCK

DESCRIPTION	PART No.	REPLACES	ACROSS FLATS	THREAD SIZE	THICKNESS	O.D.	I.D.
INNER NUT	Z-E540	Spicer M10HN158 Std. Forge 103104-001	4 <sup>1</sup> / <sub>2</sub> "	2 <sup>5</sup> / <sub>8</sub> " -16	1 <sup>1</sup> / <sub>32</sub> "	-	-
OUTER NUT	Z-E572	Spicer M103102-001 Std. Forge 103102-001	3 <sup>1</sup> / <sub>4</sub> "	2 <sup>5</sup> / <sub>8</sub> " -16	<sup>3</sup> / <sub>8</sub> "	-	-
LOCK WASHER	Z-E573	Spicer M10HN100 Std. Forge 105107	-	-	<sup>1</sup> / <sub>4</sub> "	3 <sup>15</sup> / <sub>16</sub> "	1 <sup>41</sup> / <sub>64</sub> "
TAB LOCK	Z-E2237	Spicer M10HN151 Std. Forge 105106	-	-	.060	4 <sup>1</sup> / <sub>32</sub> "	2 <sup>41</sup> / <sub>64</sub> "

# YORK AND MOSS

**490121LP** - York, Moss  
R/Owen torque rod bolt



**490120LP** - Early York,  
Moss torque rod bush

## AXLE SPINDLE SERVICE TOOL

### UNIVERSAL OUTSIDE THREAD CHASER

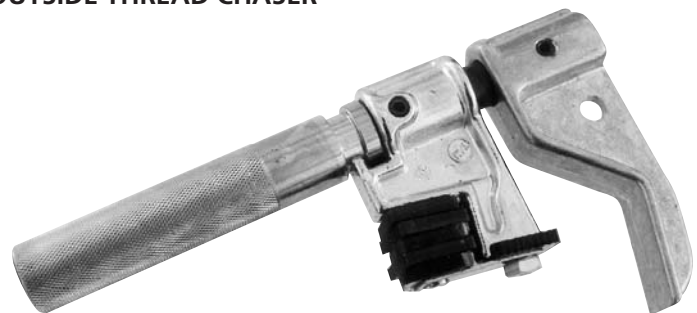
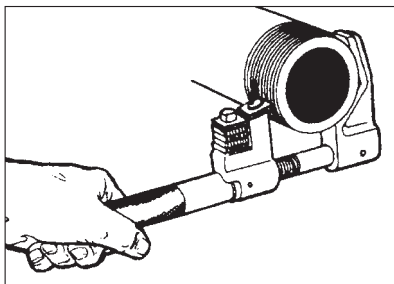

**Z-E2644** - Restores threads to their original condition. Eliminates the need for expensive thread cutting equipment.

OPERATION: Tighten the tool slightly on the good threads, then back off over the damaged thread area to restore the threads. The aluminium alloy V pad will not damage the threads. Capacity from 1 1/4" to 5" O.D.

Complete with 6 dies - Threads per inch 4, 5, 6, 7, 7 1/2, 8, 9, 10, 11, 11 1/2, 12, 14, 16, 18, 20 and 24.

# TRAILER SPRINGS

## HUTCHENS - REYCO - TRANSPRO

Z-TRA 021 (1 LEAF) low arch

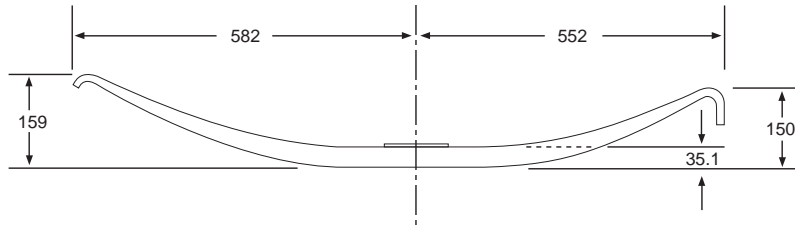

Z-TRA 023 (1 LEAF) high arch

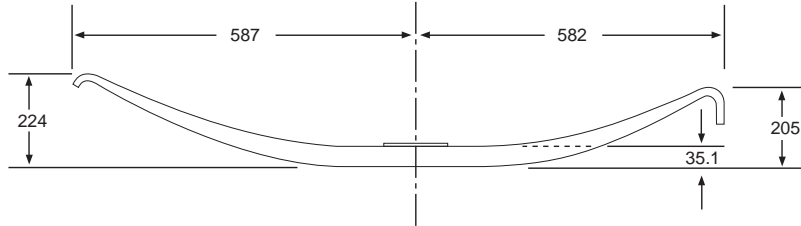

Z-160002 (2 LEAF)

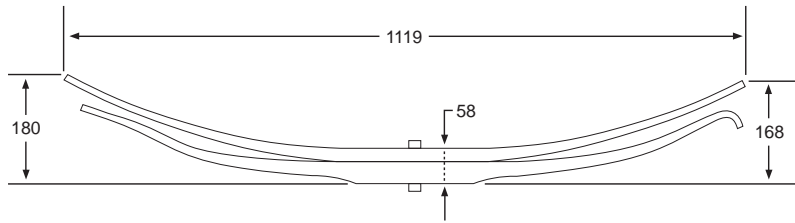

Z-TRA 2726 (3 LEAF) high arch

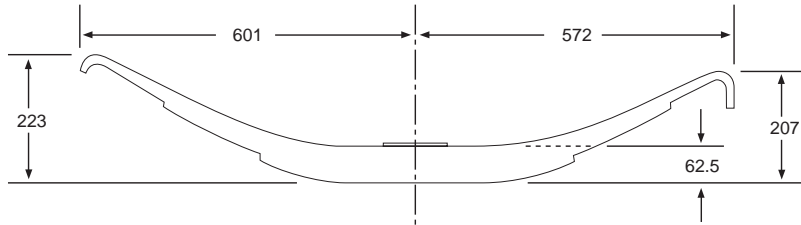

Z-TRA 2727 (3 LEAF) medium arch

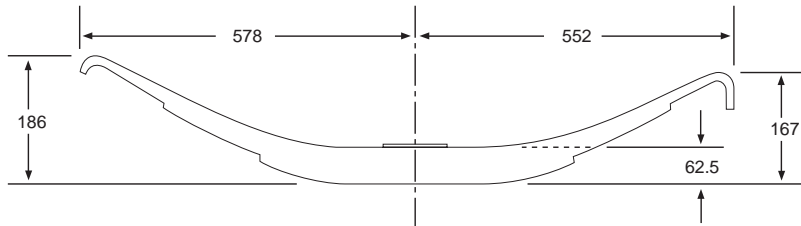

Z-TRA 2728 (3 LEAF) low arch

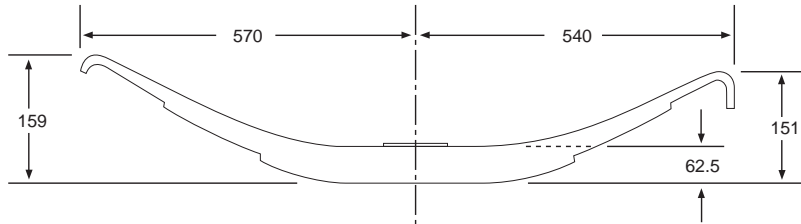

# TRAILER SPRINGS

## HUTCHENS - REYCO - TRANSPRO Continued...

Z-TRA 3310 (8 LEAF)

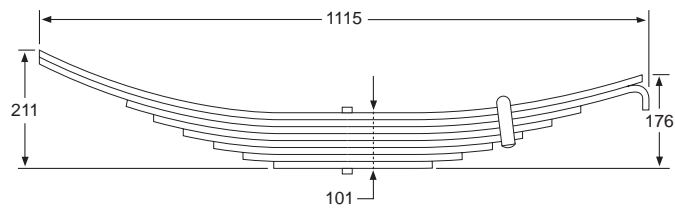

## FRUEHAUF

Z-TRA 693 (3 LEAF)

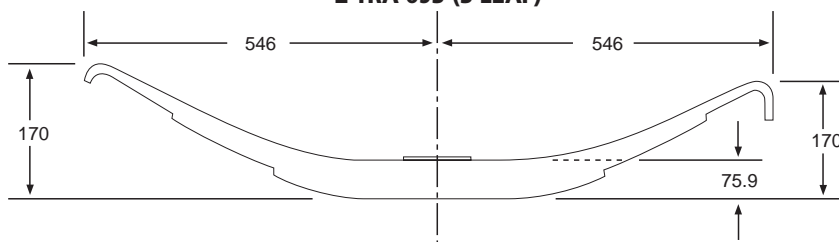

Z-TRA 2172 (8 LEAF)

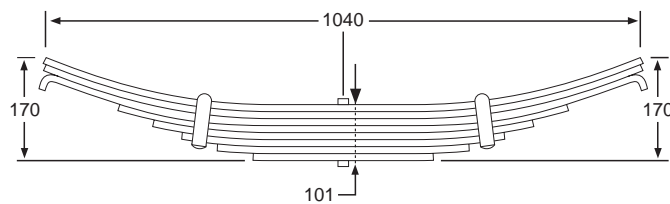

## REYCO - 21B ONLY

Z-TRA 031 (1 LEAF)

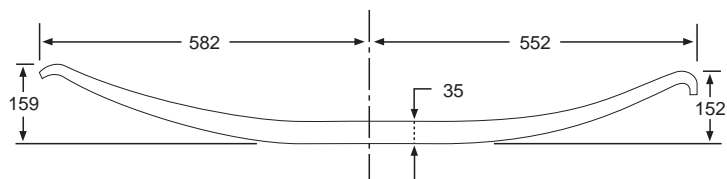

Z-TRA 2291 (3 LEAF)

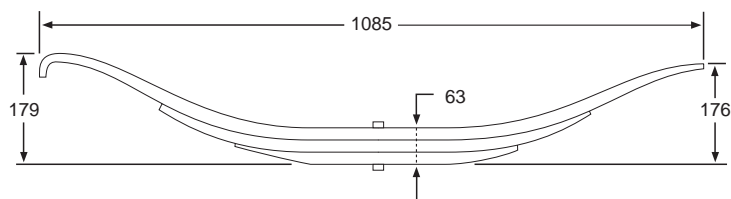

# TRAILER SPRINGS

## TRAILER REPLACEMENT SPRINGS IDENTIFICATION

### MONO LEAF

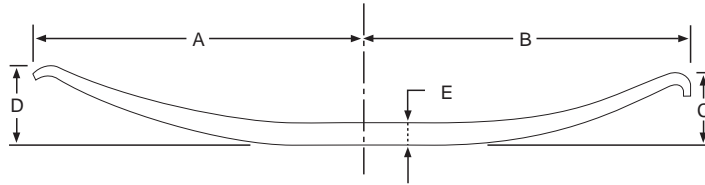

### HUTCH-TRANSPRO

PART No.	MANUFACTURERS No.	A	B	C	D	E	LOAD CAPACITY (KILOGRAMS)	WEIGHT (KILOGRAMS)	ARCH
TRA 021	0179-02 363-00	572	540	150	159	35	4627 each	17.2 each	120
TRA 023	0179-01 360-00	572	540	205	224	35	4627 each	18.5 each	181

### FRUEHAUF

PART No.	MANUFACTURERS No.	A	B	C	D	E	LOAD CAPACITY (KILOGRAMS)	WEIGHT (KILOGRAMS)	ARCH
TRA 012	UCC 7280	535	535	162	162	41	6570 each	19.8 each	120.5

### REYCO

PART No.	MANUFACTURERS No.	A	B	C	D	E	LOAD CAPACITY (KILOGRAMS)	WEIGHT (KILOGRAMS)	ARCH
TRA 031	T5555	535	552	135	135	35	4990 each	17.2 each	102

All measurements are in millimetres

# TRAILER SPRINGS

## TRAILER REPLACEMENT SPRINGS IDENTIFICATION

### 3 LEAF

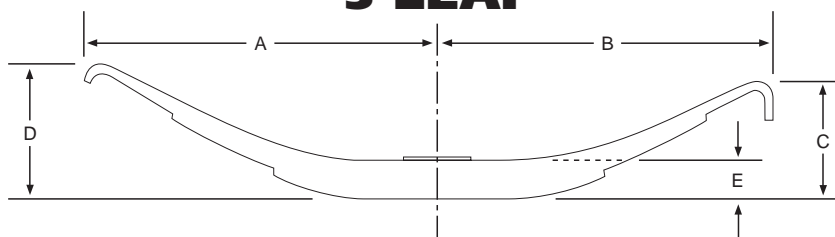

### HUTCH

PART No.	MANUFACTURERS No.	A	B	C	D	E	LOAD CAPACITY (KILOGRAMS)	WEIGHT (KILOGRAMS)	ARCH
TRA 2726	354-00	601	572	207	223	62.5	4625 each	25.5 each	152
TRA 2727	355-00	578	552	167	186	62.5	4625 each	25.3 each	114
TRA 2728	356-00	570	540	151	159	62.5	4625 each	25.3 each	92

### FRUEHAUF

PART No.	MANUFACTURERS No.	A	B	C	D	E	LOAD CAPACITY (KILOGRAMS)	WEIGHT (KILOGRAMS)	ARCH
TRA 693	UCD0511-1	546	546	170	170	75.9	4760 each	23.5 each	105

### TRANSPRO

PART No.	MANUFACTURERS No.	A	B	C	D	E	LOAD CAPACITY (KILOGRAMS)	WEIGHT (KILOGRAMS)	ARCH
TRA 3340	0079-01	613	571	200	224	63.2	4990 each	23.1 each	152
TRA 3341	0079-02	613	571	130	149.2	63.2	4990 each	23.1 each	92

All measurements are in millimetres

# AIR SPRING RANGE



**Neway Air**

5396-90054007

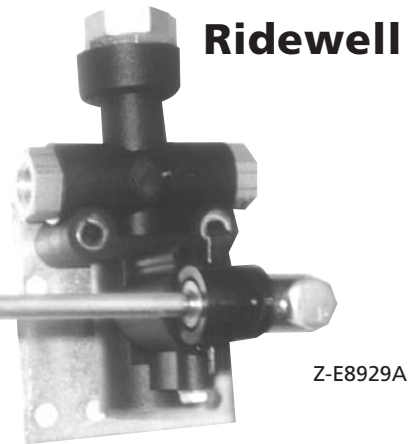

**Ridewell**

Z-E8929A

**LEVELING VALVES**  
Immediate and controlled response



**Ridewell**

(6240605)  
Z-E8929A



**Hendrickson**

Z-60501-000P



**Hendrickson**

Z-60826-000



**AIR SPRINGS**  
Truck and trailer  
types available  
(pages 39, 40)

# TRUCK & TRAILER AIR SPRING APPLICATIONS

SUSPENSION	MODEL	TRUCK STOPS PART NUMBER	BELLOWS PART NUMBER	GOODYEAR PART NUMBER	FIRESTONE PART NUMBER	REPLACES
Hendrickson	T9	B-2066	1T16M6	1R12-092	9082	Reyco 12882-01 Ridewell 1003589082C
	T15	B4771	1T19J-6 566-28-3-015	1R14-039	8050	
	T17	B-4771	1T19J-6 566-28-3-015	1R14-039	8050	
	HT1904	C-20217	1T15MLW-7	1R12-366	8944	
Single Stud	HT230	C-20010 S/S TO S-21208	1T15VM-3.5 566-26-3-036	1R13-119	9270	
Dual Stud	HT230TA	S-21208	1T15VM-3.5 566-26-3-036	1R13-119	9270	
	HT250U	C-20124	1T15-MM9	1R12-375	9265	
	HT250U-7.5-021	S-14249	1T15M-11		9367	
	HT250U-9-021	C-13122	1T19F-14	1R14-127	9264	
	HT250US	C-20127	1T15VLT-10.5 566-26-3-039 566-26-3-068	1R13-118	9262	
	HT300U	B-3830	1T19F-11 or 1T19L-11 566-26-3-015	1R13-038	9122	Reyco 12883-02 Ridewell S-3053-C

# TRUCK & TRAILER AIR SPRING APPLICATIONS

SUSPENSION	MODEL	TRUCK STOPS PART NUMBER	BELLOWS PART NUMBER	GOODYEAR PART NUMBER	FIRESTONE PART NUMBER	REPLACES
Intraax	AA230	C-20900	1T17-B5			
	AA250	C20901	1T19-FC5		8091	
ROR	Flexair FL9000L	Z-21222442	1T15MP7	1R11-106	7074	
York Ridewell	644N	B-2066	1T15M-6	1R12-092	9082	York Mack 610121 57QL310 Reyco 12882-01 1003589082C Ridewell
SAF	EM411E EU416 & EU416E	S2618C	1T17B5-6		6367	SAF SAF2618/E5
Reyco	102AR Front	S-3411 OR S-13160	1T19F-7	1R13-039	9121	Reyco 12882-02 Ridewell 5-3052-C 1003589121C
Reyco Ridewell	87/9 RAR247/7/USW	S-2827	1T15M-4	1R12-352	9010	Reyco 12928-01 Ridewell 1003589010C
Ridewell	RAR247/15/OSW	8802	1T15M-4	1R12-434	8802	Neway 90557170 Ridewell 1003588802C



# HUB CAPS & PARTS



### Z-343-4009

- Alloy hub cap with gasket
- Common trailer hub cap
- See through nylon window
- Cast alloy to resist warping



### Z-359-5999

Window Kit 2<sup>3</sup>/<sub>4</sub>" Diameter



### Z-359-5915

Vent Plug Red 3<sup>3</sup>/<sub>4</sub>"



### Z-359-5990

Vent Plug Red 1<sup>1</sup>/<sub>8</sub>"

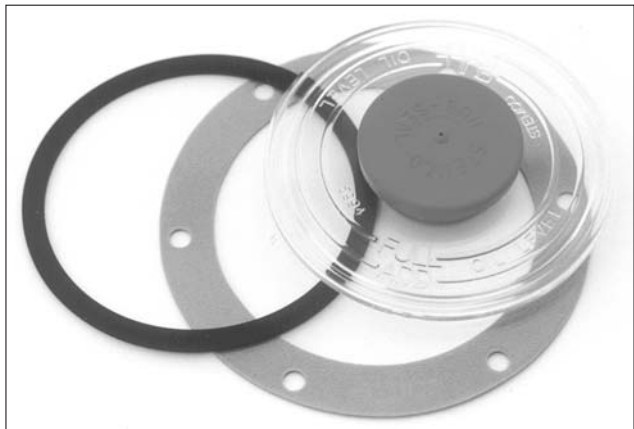

### Z-359-5995

Window Kit 3<sup>1</sup>/<sub>2</sub>" Diameter



### Z-359-6117

Window 3<sup>1</sup>/<sub>2</sub>" Diameter  
For mounting hubodometers  
Centre hole 1<sup>7</sup>/<sub>32</sub>" Diameter



### Z-359-5912

Window Kit 4<sup>3</sup>/<sub>8</sub>" Diameter

# TRAILER AXLE COMPONENTARY CHART

DESCRIPTION		INGERSOL STD FORGE				MOSS		YORK		PROPAR		RUBERY OWEN	
PART	MODEL BRAKE SIZE	A19S-A19H 16 1/2 x 7	F22 16 1/2 x 7	F22S15L.L. 12 1/4 x 7 1/2	FW22 16 1/2 x 5	MM6A715H+J 16 1/2 x 7	160 15 1/2 x 7	782 16 1/2 x 7	Low Loader 12 1/4 x 8	BMX Series 14 x 8	TM Series 16 1/2 x 7	TM 16 1/2 x 7	
1.	Bolt & Washer - Hub Cap	5/16 UNC X 1 1/2	5/16 UNC X 1 1/2	5/16 UNC X 1 1/2	5/16 UNC X 1 1/2	5/16 UNC X 1 1/2	5/16 UNC X 1 1/2	5/16 UNC X 1 1/2	-	5/16 UNC X 1 1/2	M8 X 14mm	5/16 UNC X 1 1/2	
2.	Hub Cap - Grease Filled Hub	Z-343-4009	Z-343-4009	Z-343-4009	Z-343-4009	Z-343-4009	Z-343-4009	Z-343-4009	Z-EQ0075	Z-343-4009	Z-343-4009	Z-343-4009	
2a.	Hub Cap - Steel Filled Hub	Z-343-4009	Z-343-4009	Z-343-4009	Z-343-4009	Z-343-4009	Z-343-4009	Z-343-4009	Z-EQ0075	Z-343-4009	Z-343-4009	Z-343-4009	
2b.	Hub Cap - On Flange Window (Hub)	Z-359-6117	Z-359-6117	Z-359-6117	Z-359-6117	Z-359-6117	Z-359-6117	Z-359-6117	Z-EQ0075H	Z-359-6117	Z-359-6117	Z-359-6117	
3.	Gasket - Hub Cap	94RU263	94RU263	94RU263	94RU263	94RU263	94RU263	94RU263	Z-E05500	94RU263	94RU263	94RU263	
4.	Lock Nut	Z-E572	Z-E572	Z-E572	Z-E572	Z-E572	Z-E572	Z-E572	Z-E2550	Z-E572	Z-E572	Z-E572	
5.	Lock Washer	Z-E573	Z-E573	Z-E573	Z-E573	Z-E573	Z-E573	Z-E573	Z-E1661	Z-E573	Z-E573	Z-E573	
6.	Nut - Bearing - Adjustment	Z-E540	Z-E540	Z-E540	Z-E540	Z-E540	Z-E540	Z-E540	Z-E1661	Z-E540	Z-E540	Z-E540	
7.	Bearing - Outer Cup & Cone	Z-HM212049/011	Z-HM212049/011	Z-HM212049/011	Z-HM212049/011	Z-HM212049/011	Z-HM212049/011	Z-HM212049/011	Z-HM518445/410	Z-HM211749/10	Z-HM212049/011	Z-HM212049/011	
8.	Wheel Nut R.H.	020971/ABSF	020971/ABSF	020971/ABSF	020971/ABSF	020971/ABSF	020971/ABSF	020971/ABSF	020971/ABSF	020971/ABSF	020971/ABSF	020971/ABSF	
8a.	Wheel Nut L.H.	020972/ABSF	020972/ABSF	020972/ABSF	020972/ABSF	020972/ABSF	020972/ABSF	020972/ABSF	020972/ABSF	020972/ABSF	020972/ABSF	020972/ABSF	
8b.	Wheel Nut ISO	900431107	900431107	900431107	900431107	900431107	900431107	900431107	900431107	900431107	900431107	900431107	
9.	Wheel Stud R.H.	-	-	-	-	-	-	-	-	-	-	-	
9a.	Wheel Stud L.H.	-	-	-	-	-	-	-	-	-	-	-	
10.	Lock Nut - Wheel Stud	-	-	-	-	-	-	-	-	-	-	-	
11.	Wheel Bolt R.H.	Z-837794A	Z-837794A	Z-837794A	Z-837794A	Z-837794A	Z-837794A	Z-837794A	Z-837794A	Z-837794A	Z-837794A	Z-837794A	
11a.	Wheel Bolt L.H.	Z-837793A	Z-837793A	Z-837793A	Z-837793A	Z-837793A	Z-837793A	Z-837793A	Z-837793A	Z-837793A	Z-837793A	Z-837793A	
11b.	Wheel Bolt R.H. Alloy Hub	-	-	-	-	-	-	-	-	-	-	-	
11c.	Wheel Bolt Dual Alloy Wheel	Z-837794	Z-837794	Z-837794	Z-837794	Z-837794	Z-837794	Z-837794	Z-837794	Z-837794	Z-837794	Z-837794	
11d.	Wheel Bolt Steel Wheel	Z-837794	Z-837794	Z-837794	Z-837794	Z-837794	Z-837794	Z-837794	Z-837794	Z-837794	Z-837794	Z-837794	
12.	Wheel Cone	092476-9	092476-9	092476-9	092476-9	092476-9	092476-9	092476-9	092476-9	092476-9	092476-9	092476-9	
13.	Hub - 3 Spoke	-	-	Z-7000 7" SP	Z-7000 8.5" SP	-	-	-	-	-	-	-	
13a.	Hub - 5 Spoke	Z-8920	Z-8920	Z-8920	Z-8920	Z-8920	Z-8920	Z-8920	Z-8920	Z-8920	Z-8920	Z-8920	
14.	Hub - 8 Stud 285 PCD	Z-100A-J8	Z-100A-J8	Z-100A-J8	Z-100A-J8	Z-100A-J8	Z-100A-J8	Z-100A-J8	Z-100A-J8	Z-100A-J8	Z-100A-J8	Z-100A-J8	
14a.	Hub 8 Stud STD	-	-	Z-2027 (STEEL)	Z-106448 MX (ALLOY)	-	-	-	-	-	-	-	
14b.	Hub 10 Stud 335 PCD	Z-ASH106	Z-2033	-	Z-2033	Z-03582 (LM)	Z-5001615	-	-	-	Z-03582	Z-21219784(Grease)	
14c.	Hub 10 Stud 285 PCD	Z-100A-J10	-	-	-	-	-	-	-	-	-	Z-2121162(Oil)	
14d.	Hub 10 Stud Unimount Steel 285 PCD	-	-	-	-	-	-	-	-	-	-	-	
14e.	Hub 10 Stud Unimount Alloy 285 PCD	-	-	-	-	-	-	-	-	-	-	-	
15.	Spacer Band 20 x 4 1/4	160J221AP10	160J221AP10	Z-19219 4"x15"	160J221AP10	160J221AP10	160J221AP10	160J221AP10	160J221AP10	160J221AP10	160J221AP10	160J221AP10	
15a.	Spacer Band 20 x 4 1/4	160J221AP19	160J221AP19	-	160J221AP19	160J221AP19	160J221AP19	160J221AP19	160J221AP19	160J221AP19	160J221AP19	160J221AP19	
16.	Rim Clamp - 3 Spoke	-	Z-3314	-	-	-	-	-	-	-	-	-	
16a.	Rim Clamp - 5 Spoke	Z-E5571A	Z-E5571A	Z-E5571A	Z-E5571A	Z-E5571A	Z-E5571A	Z-E5571A	Z-E5571A	Z-E5571A	Z-E5571A	Z-E5571A	
17.	Wheel Stud - Spoke	Z-E4956A	Z-E4956A	Z-E4956A	Z-E4956A	Z-E4956A	Z-E4956A	Z-E4956A	Z-E4956A	Z-E4956A	Z-E4956A	Z-E4956A	
18.	Wheel Nut - Spoke	Z-E4963BK	Z-E4963BK	Z-E4963BK	Z-E4963BK	Z-E4963BK	Z-E4963BK	Z-E4963BK	Z-E4963BK	Z-E4963BK	Z-E4963BK	Z-E4963BK	
19.	Bolt Assy - Hub To Drum - Spoke	Z-WP845	Z-WP845	Z-WP845	Z-WP845	Z-WP845	Z-WP845	Z-WP845	Z-WP845	Z-WP845	Z-WP845	Z-WP845	
20.	Brake Drum - 3 Spoke	-	-	-	-	-	-	-	-	-	-	-	
20a.	Brake Drum - 8 Stud	Z-67518F	Z-67518F	Z-67518F	Z-67518F	Z-67518F	Z-67518F	Z-67518F	Z-67518F	Z-67518F	Z-67518F	Z-67518F	
20b.	Brake Drum - 8 Stud	Z-7993 / J8 (JAP)	-	-	-	-	-	-	-	-	-	-	
20c.	Brake Drum - 8 Stud 275 PCD Webb	-	-	-	-	-	-	-	-	-	-	-	
20d.	Brake Drum - 10 Stud 285 PCD	7933 / J10 (JAP)	Z-66884	-	Z-66885	-	-	-	-	-	-	-	
20e.	Brake Drum 10 Stud STD 335 PCD	Z-663653	Z-66251	Z-66251	Z-66255	Z-66255	Z-66255	Z-66255	Z-66255	Z-66255	Z-66255	Z-66255	
21.	Bearing - Inner - Cup & Cone	Z-HM218248/210	Z-HM218248/210	Z-HM218248/210	Z-HM218248/210	Z-HM218248/210	Z-HM218248/210	Z-HM218248/210	Z-HM518445/410	Z-HM218248/210	Z-HM218248/210	Z-HM218248/210	
22.	Seal Grease Filled Hub	Z-CR40136S	Z-CR40136S	Z-CR40136S	Z-CR40136S	Z-CR40136S	Z-CR40136S	Z-CR40136S	Z-CR42622S	Z-CR40136S	Z-CR40136S	Z-CR40136S	
22a.	Seal Oil Filled Hub	Z-CR40136S	Z-CR40136S	Z-CR40136S	Z-CR40136S	Z-CR40136S	Z-CR40136S	Z-CR40136S	Z-CR42622S	Z-CR40136S	Z-CR40136S	Z-CR40136S	
22b.	Seal - Scot Seal Plus	Z-CR40129S	Z-CR40129S	Z-CR40129S	Z-CR40129S	Z-CR40129S	Z-CR40129S	Z-CR40129S	Z-CR42622S	Z-CR40129S	Z-CR40129S	Z-CR40129S	
22c.	Seal - Scot Seal Plus	Z-CR40129S	Z-CR40129S	Z-CR40129S	Z-CR40129S	Z-CR40129S	Z-CR40129S	Z-CR40129S	Z-CR42622S	Z-CR40129S	Z-CR40129S	Z-CR40129S	
23.	Cam Shaft R.H.	Z-E1425	Z-E1425	Z-E1425	Z-E1425	Z-E1425	Z-E1425	Z-E1425	Z-E1564	Z-E1425	Z-E1425	Z-E1425	
23a.	Cam Shaft L.H.	Z-E1425	Z-E1425	Z-E1425	Z-E1425	Z-E1425	Z-E1425	Z-E1425	Z-E1564	Z-E1425	Z-E1425	Z-E1425	
23b.	Cam Shaft R.H. Long	Z-E1094	Z-E1094	Z-E1094	Z-E1094	Z-E1094	Z-E1094	Z-E1094	Z-E1564	Z-E1094	Z-E1094	Z-E1094	
23c.	Cam Shaft L.H. Long	Z-E1095	Z-E1095	Z-E1095	Z-E1095	Z-E1095	Z-E1095	Z-E1095	Z-E1564	Z-E1095	Z-E1095	Z-E1095	
24.	Washer - Cam Shaft	Z-E2469	Z-E2469	Z-E2469	Z-E2469	Z-E2469	Z-E2469	Z-E2469	Z-E2122 (EM)	Z-E2469	Z-E2122 (EM)	Z-E2122 (EM)	
25.	O-Ring Seal	Z-E2469	Z-E2469	Z-E2469	Z-E2469	Z-E2469	Z-E2469	Z-E2469	Z-E2122 (EM)	Z-E2469	Z-E2122 (EM)	Z-E2122 (EM)	

26.	Nylon Bush	Z-E2469	Z-E2469	Z-E2469	Z-E2469	Z-E1357A	Z-E1357A	Z-E2469	Z-E2122 (EM) Z-E2090 (LM)	Z-AXL132	Z-E1357A	Z-AXL122	Z-AXL132
27.	O'Ring Seal	Z-E2469	Z-E2469	Z-E2469	Z-E2469	Z-E1357A	Z-E1357A	Z-E2469	Z-E2122 (EM) Z-E2090 (LM)	Z-AXL132	Z-E1357A	Z-AXL122	Z-AXL132
28.	Washer - CamShaft	Z-E2469	Z-E2469	Z-E2469	Z-E2469	Z-E1357A	Z-E1357A	Z-E2469	Z-E2122 (EM) Z-E2090 (LM)	Z-AXL132	Z-E1357A	Z-AXL122	Z-AXL132
29.	CircJin - CamShaft	Z-E5206	Z-E5206	Z-E5206	Z-E5206	Z-E5206	Z-E5206	Z-E5206	Z-E5206	Z-AXL132	Z-E5206	Z-AXL122	Z-AXL132
30.	Bracket - CamShaft	Z-E2385	Z-E2385	Z-E2385	Z-E2385	Z-E603	Z-E603	Z-E2385	Z-E2122 (EM) Z-E2090 (LM)	Z-AXL132	Z-E603	Z-AXL122	Z-AXL132
31.	O'Ring	Z-E2469	Z-E2469	Z-E2469	Z-E2469	Z-E1357A	Z-E1357A	Z-E2469	Z-E2122 (EM) Z-E2090 (LM)	Z-AXL132	Z-E1357A	Z-AXL122	Z-AXL132
32.	Nylon Spherical Bearing	Z-E2469	Z-E2469	Z-E2469	Z-E2469	Z-E1357A	Z-E1357A	Z-E2469	Z-E2122 (EM) Z-E2090 (LM)	Z-AXL132	Z-E1357A	Z-AXL122	Z-AXL132
33.	Stack Adjuster	Z-2500D243P5	Z-2500D243P5	Z-2500D243P5	Z-2500D243P5	Z-2500D243P5	Z-2500D243P5	Z-2500D243P5	Z-E1574BK Z-E2122 (EM) Z-E2090 (LM)	Z-2500D243P5	Z-2500D243P5	Z-2500D243P5	Z-2500D243P5
34.	Washer - CamShaft	Z-E2469	Z-E2469	Z-E2469	Z-E2469	Z-E1357A	Z-E1357A	Z-E2469	Z-E2122 (EM) Z-E2090 (LM)	Z-AXL132	Z-E1357A	Z-AXL122	Z-AXL132
35.	Washer - CamShaft	Z-E2469	Z-E2469	Z-E2469	Z-E2469	Z-E1357A	Z-E1357A	Z-E2469	Z-E2122 (EM) Z-E2090 (LM)	Z-AXL132	Z-E1357A	Z-AXL122	Z-AXL132
36.	Brake Shoe Only	Z-E2241	Z-E2241	Z-E2241	Z-E2241	Z-E241	Z-E241	Z-E241	Z-E241	-	Z-E241	-	Z-E241
36a.	Brake Shoe Only OR	Z-A3222S1293	Z-A3222S1293	Z-E5303A	Z-A3222S1293	Z-A3222S1293	Z-A3222S1293	Z-A3222S1293	Z-A3222S1293	Z-A3222S1293	Z-A3222S1293	Z-A3222S1293	Z-A3222S1293
37.	Brake Liming - Axle Set	4515	4692	4692	4692	4515	4515	4515	4515	Z-8L168R	4515	4515	4515
38.	Brake Liming Rivets - Axle Set	Z-R147AL	Z-R147AL	Z-R147AL	Z-R147AL	Z-R147AL	Z-R147AL	Z-R147AL	Z-R147AL	Z-R147AL	Z-R147AL	Z-R147AL	Z-R147AL
39.	Anchor Pin OR	Z-E512BK	Z-E2402HD	Z-E3782	Z-E3782	Z-R509000	Z-R509000	Z-R509000	Z-R509000	Z-AXL126	Z-R509000	Z-AXL125	Z-R509000
39a.	Anchor Pin OR	Z-KIT18000	Z-E2402HD	Z-E3782	Z-E3782	Z-KIT18000	Z-KIT18000	Z-KIT18000	Z-KIT18000	Z-AXL126	Z-KIT18000	Z-AXL125	Z-KIT18000
40.	Bush Anchor Pin	Z-R509000	Z-R509000	Z-E3782	Z-E3782	Z-R509000	Z-R509000	Z-R509000	Z-R509000	Z-AXL126	Z-R509000	Z-AXL125	Z-R509000
41.	Washer - Anchor Pin	Z-1290D2942	Z-E2402HD	Z-E3782	Z-E3782	Z-1290D2942	Z-1290D2942	Z-1290D2942	Z-1290D2942	Z-AXL126	Z-R509000	Z-AXL125	Z-R509000
42.	Clip - Anchor Pin	Z-E1880B	Z-E2398	Z-E2398	Z-E2398	Z-E1880B	Z-E1880B	Z-E1880B	Z-E1880B	Z-AXL126	Z-E1880B	Z-E1880B	Z-E1880B
43.	Return Spring OR	Z-E1880B	Z-E2398	Z-E2398	Z-E2398	Z-E1880B	Z-E1880B	Z-E1880B	Z-E1880B	Z-AXL126	Z-E1880B	Z-E1880B	Z-E1880B
43a.	Return Spring OR	Z-KIT18002SS	Z-E2402HD	Z-E3782	Z-E3782	Z-KIT18002SS	Z-KIT18002SS	Z-KIT18002SS	Z-KIT18002SS	Z-AXL126	Z-KIT18002SS	Z-R509000	Z-KIT18002SS
44.	Pin - Return Spring	Z-R509000	Z-E2402HD	Z-E3782	Z-E3782	Z-R509000	Z-R509000	Z-R509000	Z-R509000	Z-AXL126	Z-R509000	Z-R509000	Z-R509000
45.	Cam Roller STD	Z-1779R18	Z-2402HD	Z-R1779R18	Z-1779R18	Z-1779R18	Z-1779R18	Z-1779R18	Z-1779R18	Z-AXL126	Z-1779R18	Z-1779R18	Z-1779R18
46.	Cam Roller Retainer	Z-3105B210	Z-E2402HD	Z-3105B210	Z-3105B210	Z-3105B210	Z-3105B210	Z-3105B210	Z-3105B210	Z-AXL126	Z-3105B210	Z-3105B210	Z-3105B210
46a.	Cam Roller Circlip	Z-E527	Z-E527	Z-E527	Z-E527	Z-E527	Z-E527	Z-E527	Z-E527	-	-	-	-
49.	Dust Cover	Z-E886	Z-E886	Z-E886	Z-E886	Z-E886	Z-E886	Z-E886	Z-E886	Z-212097056	Z-E886	Z-21224518/22	Z-E886
	Brake Shoe Repair Kit OR	Z-KIT18000	Z-E2402HD	Z-E3782	Z-E3782	Z-KIT18000	Z-KIT18000	Z-KIT18000	Z-KIT18000	Z-AXL126	Z-KIT18000	Z-AXL125	Z-KIT18000
	Brake Shoe Repair Kit P	Z-R509000	Z-E2469	Z-E2469	Z-E2469	Z-R509000	Z-R509000	Z-R509000	Z-R509000	Z-AXL126	Z-R509000	Z-AXL125	Z-R509000
	Cam Shaft Repair Kit	Z-E2469	Z-E2469	Z-E2469	Z-E2469	Z-E1357A	Z-E1357A	Z-E2469	Z-E2122 (EM) Z-E2090 (LM)	Z-AXL132	Z-E1357A	Z-AXL122	Z-AXL132

(EM) = EARLY MODEL (LM) = LATE MODEL (LL) = LOW LOADER AXLE (SP) = SPIGOT

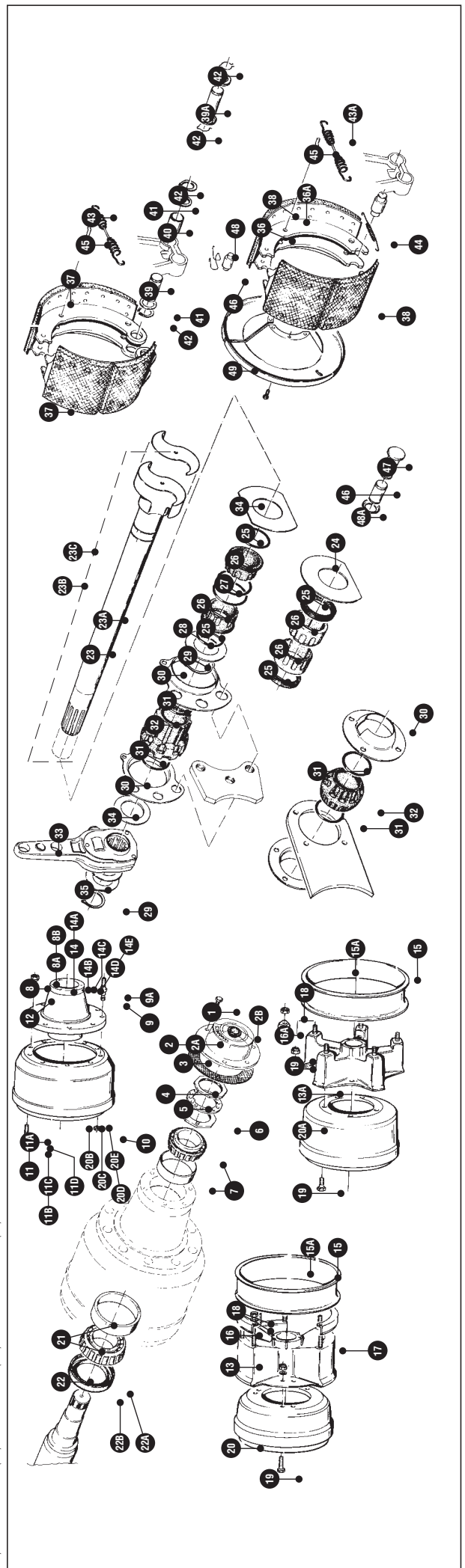

# TRAILER

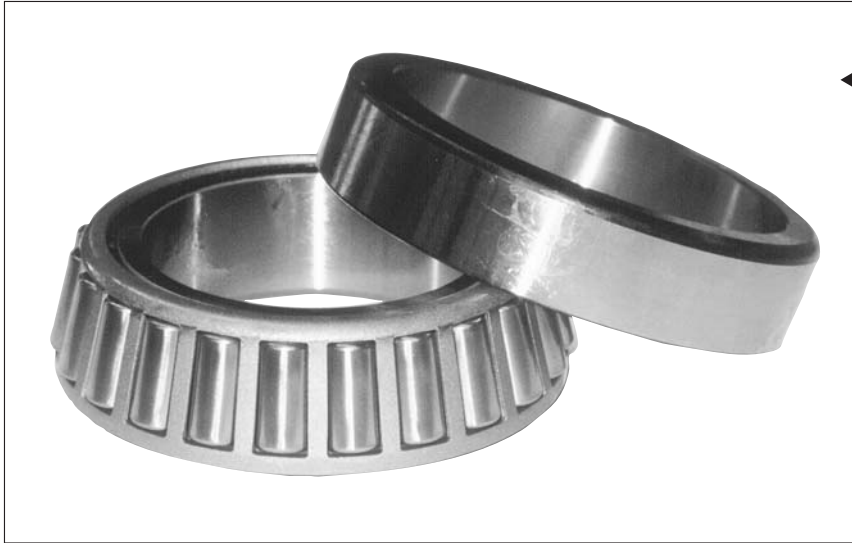

← **TAPERED  
ROLLER  
BEARINGS**



**CR SCOTSEAL** →



← **CR HUBCAP**

# TRAILER WHEEL BEARINGS, SEALS & HUBCAPS

MAKE OF AXLE	INNER CONE	INNER CUP	OUTER CONE	OUTER CUP	SCOTSEAL	SCOTSEAL PLUS XL	HUB CAP	HUB CAP GASKET
AUSTRALIAN TANNER A.T.N.	Z-HM218248 ● B/S	Z-HM218210 ● B/S	Z-HM212049 * B/S	Z-HM212011 * B/S	Z-CR46305S	Z-CR46300S	Z-CR1743 OR Z-343-4009	7843-3303009
BPW EHZ9000	Z-33217 (Assy)	Z-33217 (Assy)	Z-JH211749	Z-JH211710				
BPW EHZ12000	Z-33118 (Assy)	Z-33118 (Assy)	Z-JH211749	Z-JH211710				
DANA 15" & 20"	Z-665A	Z-653	Z-HM212049 * B/S	Z-HM212011 * B/S	Z-CR46305S	Z-CR46300S	Z-CR1743 OR Z-343-4009	7843-3303009
FRUEHAUF PROPAP SQUARE AXLE	Z-HM518445 ■ B/S	Z-HM518410 ■ B/S	Z-HM518445 ■ B/S	Z-HM518410 ■ B/S	Z-CR42623S	Z-CR42627S	Z-E04075	Z-E05500
HUNTON TYPE 16	Z-HM218248 ● B/S	Z-HM218210 ● B/S	Z-HM212049 * B/S	Z-HM212011 * B/S	Z-372-7050 OIL FILLED		Z-CR1743 OR Z-343-4009	7843-3303009
INGERSOL A19S20 A19S15 LOW LOADER	Z-663	Z-653	Z-HM212049 * B/S	Z-HM212011 * B/S	Z-CR40136S	Z-CR40129S	Z-CR1743 OR Z-343-4009	7843-3303009
INGERSOL A22S20 F22 FW22 F22S15 LOW LOADER F22MX LOW LOADER	Z-HM218248 ● B/S	Z-HM218210 ● B/S	Z-HM212049 * B/S	Z-HM212011 * B/S	Z-CR46305S	Z-CR46300S	Z-CR1743 OR Z-343-4009	7843-3303009
MOSS IMPERIAL	Z-665A	Z-663	Z-641	Z-632	Z-CR43752S		N.L.A.	
MOSS METRIC AND LOW LOADER	Z-HM218248 ● B/S	Z-HM218210 ● B/S	Z-33213 (Assy)	Z-33213 (Assy)	Z-CR46305S	Z-CR46300S	Z-CR1743 OR Z-343-4009	7843-3303009
ROCKWELL ATN5 15"	Z-HM218248 ● B/S	Z-HM218210 ● B/S	Z-HM212049 * B/S	Z-HM212011 * B/S	Z-CR46305S	Z-CR46300S	Z-CR1743 OR Z-343-4009	7843-3303009

# TRAILER WHEEL BEARINGS, SEALS & HUBCAPS

MAKE OF AXLE	INNER CONE	INNER CUP	OUTER CONE	OUTER CUP	SCOTSEAL	SCOTSEAL PLUS XL	HUB CAP	HUB CAP GASKET
RUBERY OWEN "UT" SERIES IMPERIAL	Z-665A	Z-653	Z-641	Z-632	Z-CR43752S		Z-CR1743 OR Z-343-4009	7843-3303009
RUBERY OWEN "TM" SERIES METRIC "TM" LOW LOADER "BMX" SERIES	Z-HM218248 ● B/S	Z-HM218210 ● B/S	Z-33213 (Assy)		Z-CR46305S	Z-CR46300S	Z-CR1743 OR Z-343-4009	7843-3303009
TANNER 10 TON (UP TO 1982)	Z-580	Z-572X	Z-567A	Z-563	Z-CR43691		Z-CR1743	7843-3303009
TANNER 10 TON (FROM 1982)	Z-HM218248 ● B/S	Z-HM218210 ● B/S	Z-HM212049 * B/S	Z-HM212011 * B/S	Z-CR46305S	Z-CR46300S	Z-CR1743	7843-3303009
TANNER 15-1015 LOW LOADER	Z-HM218248 ● B/S	Z-HM218210 ● B/S	Z-HM212049 * B/S	Z-HM212011 * B/S	Z-CR46305S	Z-CR46300S	Z-CR1743 OR Z-343-4009	7843-3303009
YORK 160 20"	Z-HM218248 ● B/S	Z-HM218210 ● B/S	Z-JH211749	Z-JH211710	020102LP Z-372-7050	GREASE TYPE OIL TYPE	Z-CR1743 OR Z-343-4009	7843-3303009
YORK 160 LOW LOADER	Z-HM218248 ● B/S	Z-HM218210 ● B/S	Z-33213 (Assy)		Z-372-7050		Z-CR1743 OR Z-343-4009	7843-3303009

\* Available in bearing sets: Z-HM212049/011

● Available in bearing sets: Z-HM218248/210

■ Available in bearing sets: Z-HM518445/410