

EXHAUST SYSTEM COMPONENTS

ELBOWS

90° ELBOW
3" TO 5" O.D. BOTH ENDS
16 GAUGE MATERIAL

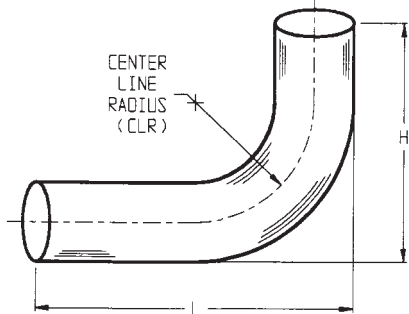

PLAIN STEEL PART No.	DIAMETER	L	H	CLR
Z-AP300	3"	9½"	9½"	6"
Z-AP351212	3½"	12"	12"	5"
Z-AP400	4"	13"	13"	8"
Z-AP508	5"	13½"	13½"	8"

SHORT RADIUS 90° ELBOW
O.D. BOTH ENDS

Designed for welding, where real tight bends are required. Available in 3 popular sizes. Inlet and outlet are O.D. 16 GA. 5" are 14 GA.

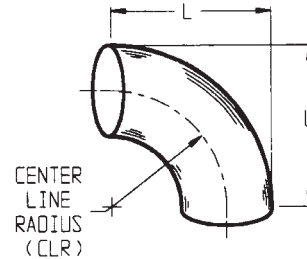

PLAIN STEEL PART No.	DIAMETER	L	CLR
Z-C300	3"	4½"	3"
Z-C350	3½"	5½"	3½"
Z-C400	4"	6"	4"
Z-C500	5"	7½"	5½"

90° ELBOW
3" TO 5" ONE END O.D. - ONE END I.D.
16 GAUGE MATERIAL

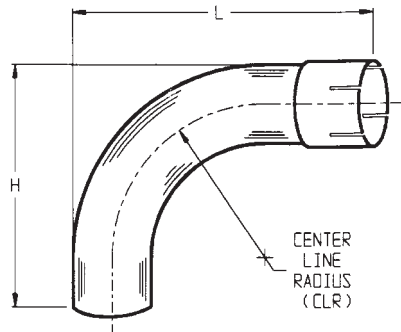

PART No.	DIAMETER	L	H	CLR
Z-A300 Steel	3"	9½"	9½"	6"
Z-A351212	3½"	12"	12"	5"
Z-A41212A Aluminized	4"	12"	12"	6"
Z-A508 Steel	5"	13½"	13½"	8"
Z-A52020 Steel	5"	20"	20"	8"

SPECIAL SHORT RADIUS 90° ELBOW
INLET AND OUTLET ARE O.D.

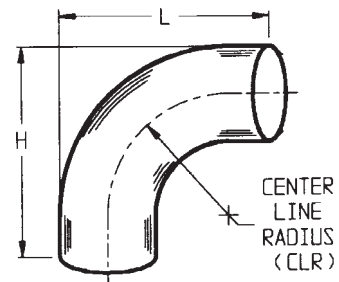

PLAIN STEEL PART No.	DIAMETER	L	H	RADIUS
Z-D302	3"	6½"	6½"	3"
Z-D352	3½"	7¼"	7¼"	3½"
Z-D402	4"	8"	8"	4"
Z-D503	5"	10½"	10½"	5½"

EXHAUST SYSTEM COMPONENTS

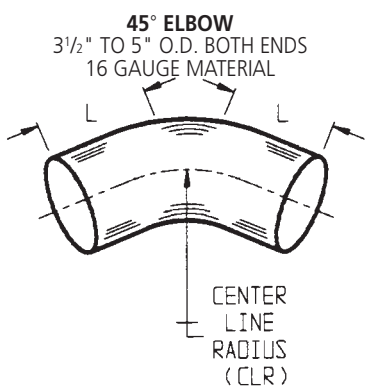

PLAIN STEEL PART No.	DIAMETER	L	CLR
Z-BP3545L	3 1/2"	9 1/4"	7"
Z-BP445	4"	6"	8"
Z-BP5458	5"	6 5/16"	8"

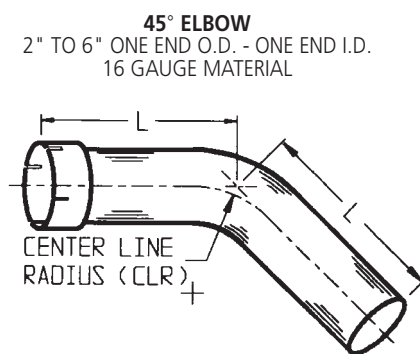

PLAIN STEEL PART No.	DIAMETER	L	CLR
Z-B345	3"	6"	6"
Z-B3545	3 1/2"	6"	7"
Z-B445L	4"	9"	6"
Z-B5458L	5"	9"	8"