

SPICER UNI-JOINT KITS

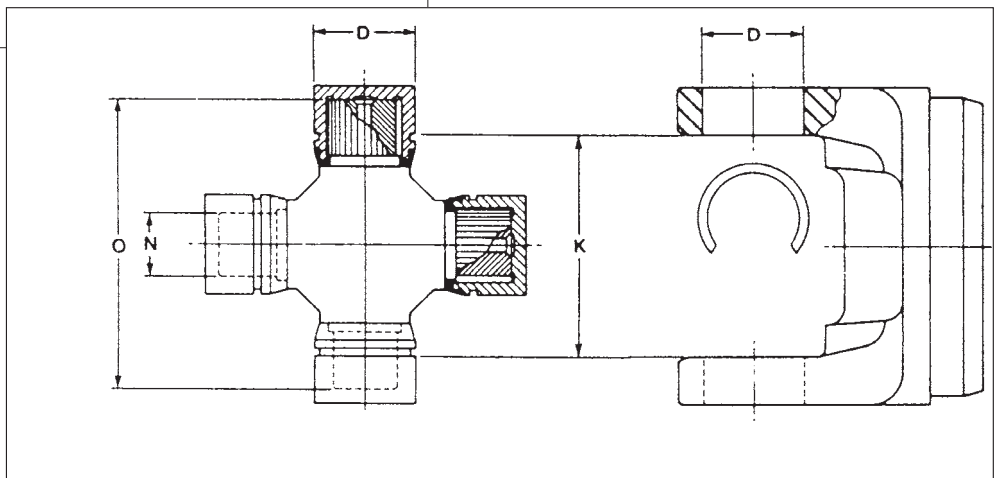

INSIDE SNAP RING STYLE REPLACEMENT KITS



K		D		N	O	Lube Fitting	Original Equipment		Spicer Part No.
Snap Ring Dimension		Bearing Diameter		Cross Trunnion Diameter	Cross Overall Length		Manufacturer	Series	
Inches	mm	Inches	mm						
1.500"		.938"		.505"	2.078"	Yes	Spicer	1000-SG	Z-5103X

SPICER UNI-JOINT KITS



2 OUTSIDE SNAP RING & 2 WING BEARING STYLE CONVERSION REPLACEMENT KITS

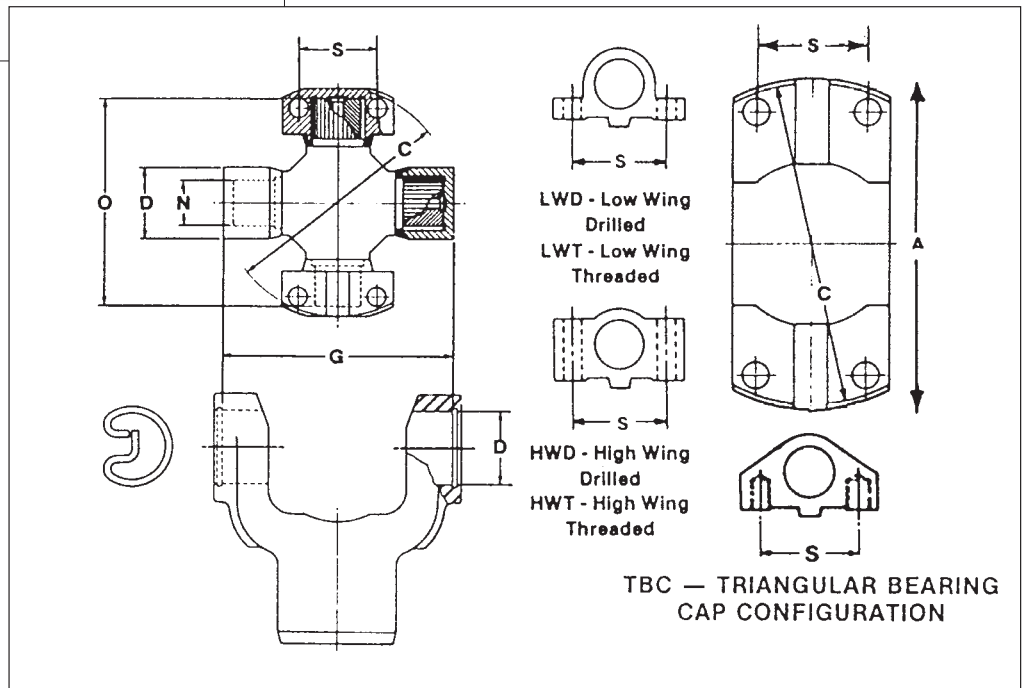

C	S	G	D	N	O	Wing and Round Bearing Type	In Order to Convert		Spicer Part No. (Contains Lube Fitting)
							From Mechanics / Rockwell Series	To Spicer Series	
Pilot Diameter	Centerline to Centerline Bearing Bolt Hole	Snap Ring Dimension	Bearing Diameter	Cross Trunnion Diameter	Cross Overall Length				
8.250"	2.813"	8.094"	2.185"	1.380"	7.594"	2 (HWD) 2 Round	9C/92N 88WB	1880	Z-5186X

SPICER UNI-JOINT KITS

2 WING BEARING & 2 BEARING PLATE STYLE CONVERSION REPLACEMENT KITS

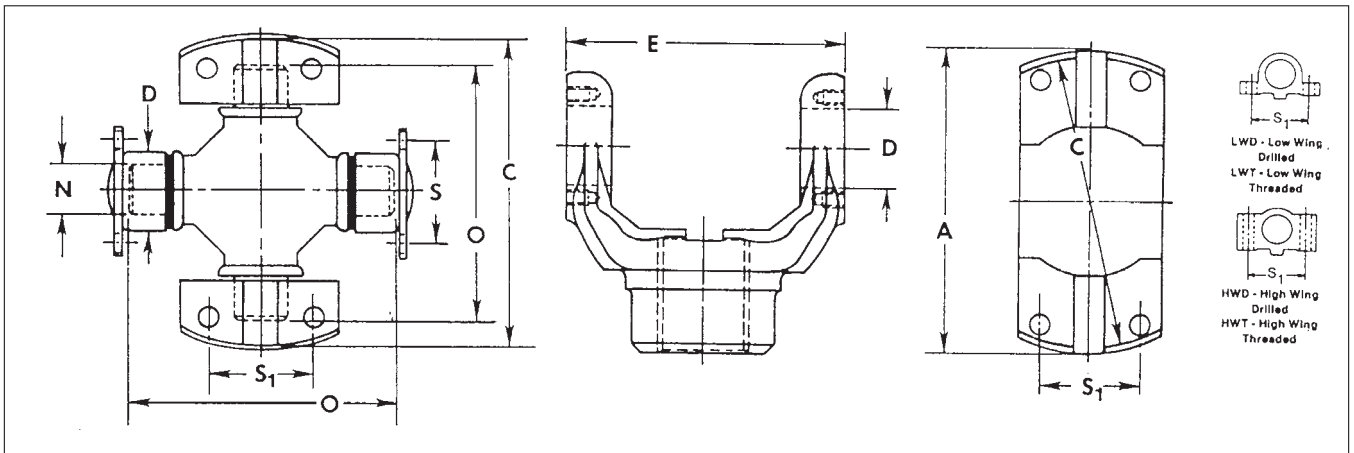
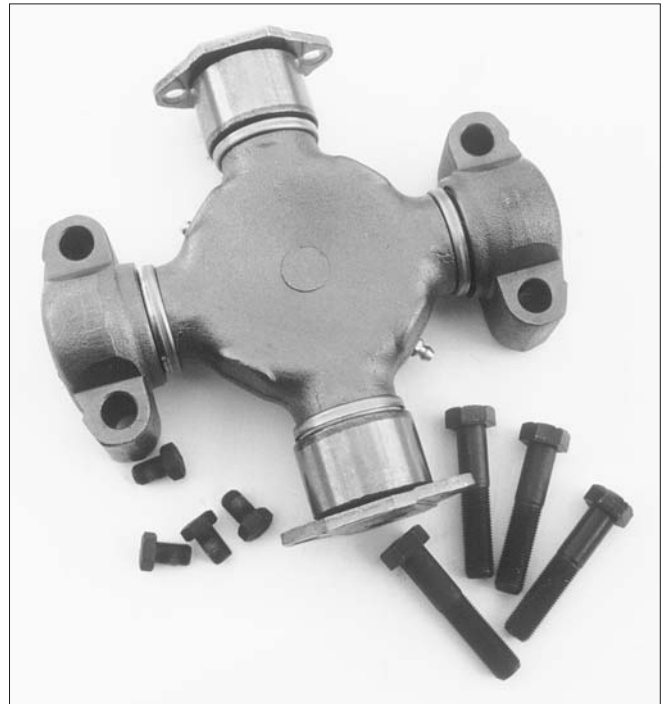

C	S ₁	E	D	S	N	O	Wing and Bearing Plate Type	A	In Order to Convert		Spicer Part No. (Contains Lube Fitting)
									From Mechanics Rockwell Series	To Spicer Series	
Pilot Diameter	Wing Centerline to Centerline Bearing Bolt Hole	Yoke Dimension	Bearing Diameter	Bearing Plate Centerline to Centerline Bearing Bolt Hole	Cross Trunnion Diameter	Cross Overall Length		Swing Diameter			
8.250"	2.813"	7.547"	1.938"	2.438"	1.300"	7.250"	2 (HWD) 2B/P	8.375	9C/92N 88WB	1810	Z-5324X
8.250"	2.813"	8.094"	2.187"	2.813"	1.380"	7.594"	2 (HWD) 2B/P	8.375	9C/92N 88WB	1880	Z-5326X

SPICER UNI-JOINT KITS



BEARING PLATE STYLE REPLACEMENT KITS

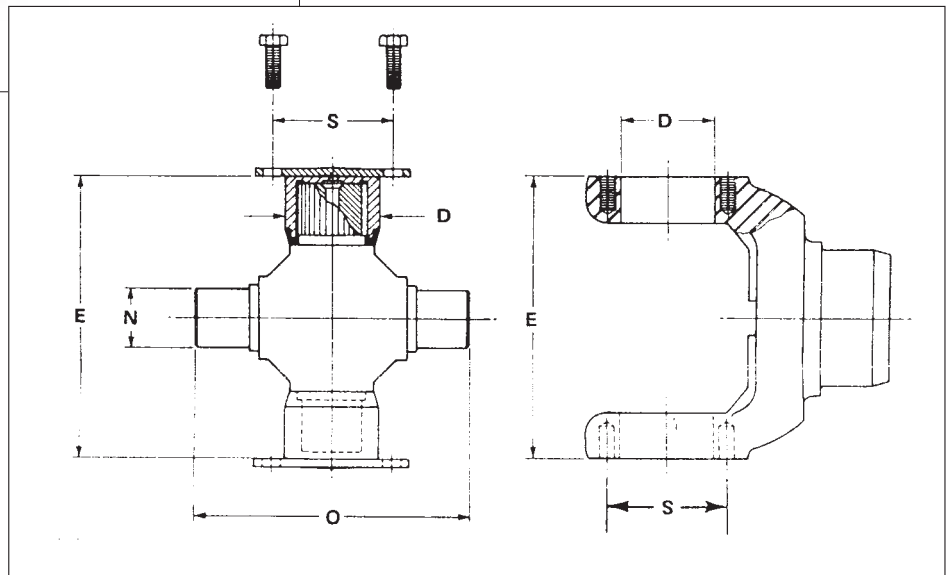

E Yoke Dimension	D Bearing Diameter	S Centerline to Centerline Bearing Bolt Hole	N Cross Trunnion Diameter	O Cross Overall Length	Original Equipment		Spicer Part No. (Contains Lube Fitting)
					Manufacturer	Series	
5.312"	1.875"	2.308"	1.272"	5.001"	Spicer	1610	Z-5279X
6.094"	1.937"	2.432"	1.298"	5.784"	Spicer	1710	Z-5280X
6.594"	2.312"	2.432"	1.681"	6.283"	Spicer	1800	Z-5124X
7.547"	1.937"	2.432"	1.298"	7.242"	Spicer	1810	Z-5281X

SPICER UNI-JOINT KITS

2 BEARING PLATE, 2 STRAP STYLE BEARING AND HALF ROUND REPLACEMENT KITS



**BEARING
RETAINER
STRAP KIT**
• 1/2 Round
• Suits 1810 Drive Line

Part No. Z-657018X

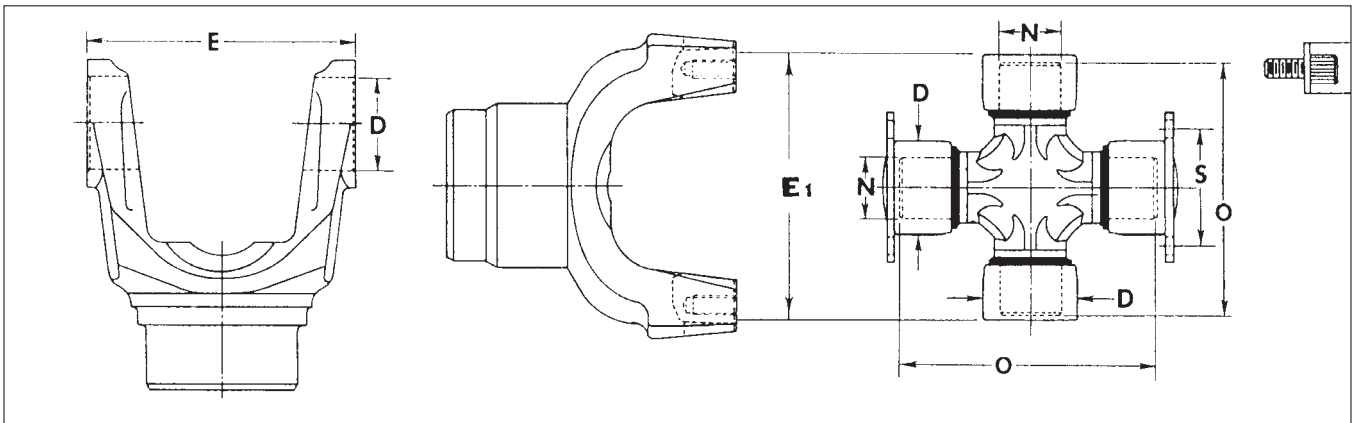

E	E ₁	D	S	N	O	Original Equipment		Spicer Part No. (Contains two Lube Fittings)
						MFG.	Series	
Yoke Dimension	Yoke Dimension	Bearing Diameter	Centerline to Centerline Bearing Bolt Hole	Cross Trunnion Diameter	Cross Overall Length	Spicer	1710	Z-5675X
6.094"	6.094"	1.937"	2.432"	1.298"	5.784"	Spicer	1810	Z-5676X

The value of Powertrain® replacement U-Joints

SPICER®

Thrust pad minimises wear.

Bearing Race I.D. crowning reduces trunnion galling and flaking and compensates for yoke deflection.

Lube Retention Valve maintains lubricant in bearing area.

Uniform case hardening provides maximum wear surface and resists surface distortion.

Forged journal cross, carburized and hardened for extended service.

Grooved trunnions ensure maximum flow of grease to needle bearings.

Tapered Roller Ends ensure needle retention.

Grease fitting facilitates maintenance.

Bearing with "Long Life" Seals retains lubrication and excludes harmful

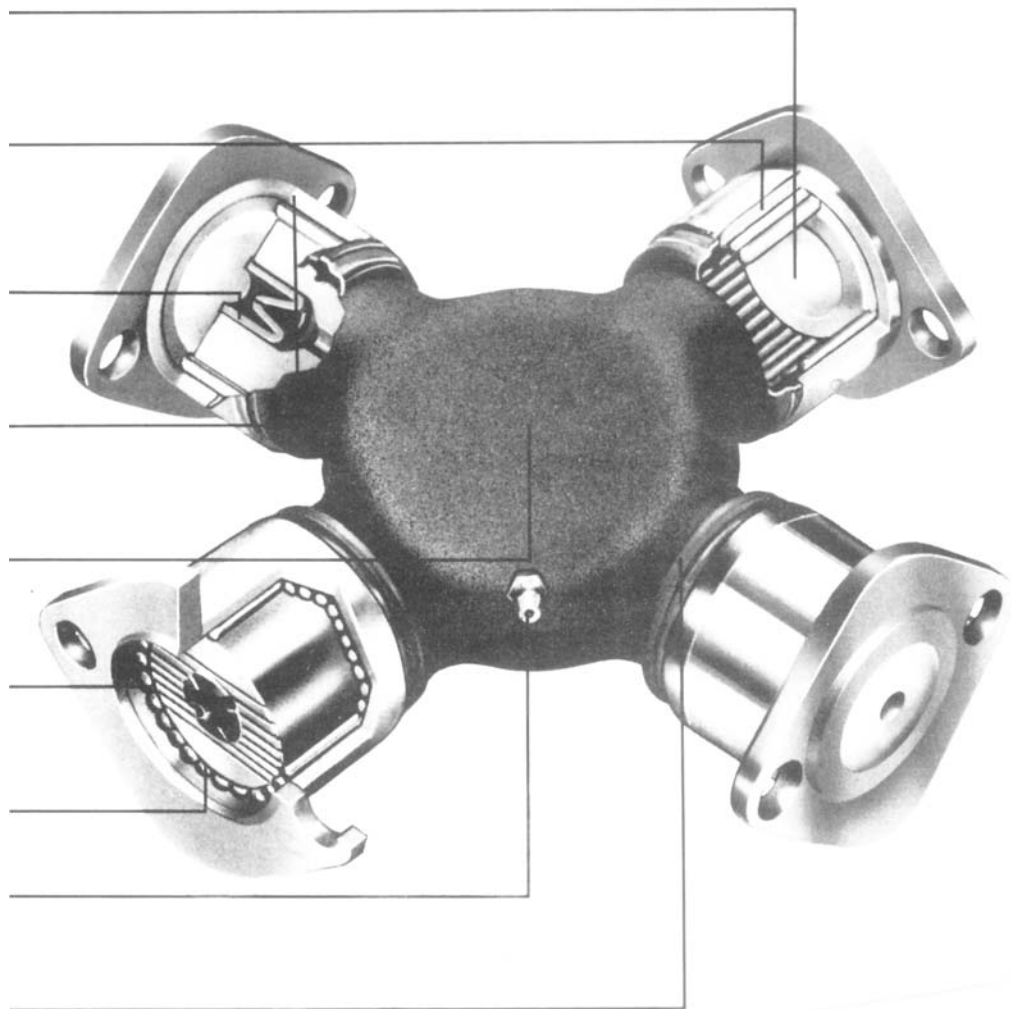

Z-279 for 1610 Series
Z-280 for 1710 Series
Z-281 for 1810 Series



Powertrain.® Because anything less than Dana technology isn't worth the chance.