

BRAKING

• Brake Linings	1
• Disc Pads	6
• Disc Rotor	6
• Brake Drums	7
• Spring Brake Chambers	8
• Slack Adjusters	9
• Sealco	10
• Bendix Valves	13
• Wabco Valves	14

S E C T I O N

E

Brake Lining Sets

**Rockwell International • Fruehauf • Freightliners • Navistar
Eaton • Mack Trucks • Dana**
American, European, Japanese Trucks and Trailer Units

BLOCK No.	DRUM DIA	WIDTH	THICKNESS	LENGTH	USE
1308	15"	4	.438	16.5	Kenworth & International front axle (A straight lining)
4311	15.5	7	.750	8.5	Eaton axles/Standard Forge
4375	17.5	4	.500	15.63	Eaton
4515	16.5	7	.750 (Tapered)	8.13 8.38	Fruehauf, Mack, Standard Forge, Eaton, Dana, Rockwell, ERF, C Series Rear. <i>(Fits most American truck rear axles & most trailer axles).</i>
4524	16.5	5	.750 (Tapered)	8.13 8.38	Front axle for Mack, KW, Freightliner, Inter, fits most American front axles that use tapered linings.
4591	12.25	7.5	.750 (Tapered)	6 6	Dana, Eaton, Standard Forge
4625	16.5	7	.750 (Tapered)	8.88 9.00	Rockwell/Mack Heavy Weight (Old style)
4630	18.5	7	.750	10.25	KW (off road with Clarke diffs) Wagner loaders (with Clarke diffs)
4649	12.25	8	.750 (Tapered)	6.06 6.26	Fruehauf
4656	410mm	160mm	18.2/15.7mm	190mm 230mm	Man, Mercedes Benz Bus
4657	410mm	220mm	18.2/15.7mm	190mm 230mm	Man, Mercedes Benz Bus
4662	15.5	6	.750 (Tapered)	6.5 8.25	Volvo Bus
4664	15.5	8	.750 (Tapered)	8.19 6.31	Volvo Bus
4692	12.25	7.5	.750 (Tapered)	6 6	Dana
4709	419.1mm	177.8mm	22.2mm	207mm	Trailer Axles

Brake Lining Drillings (All measurements in inches unless shown otherwise)

Brake Lining Sets

PART No.	DRUM DIA	WIDTH	THICKNESS	LENGTH	COF	MAKE OF VEHICLE
Z-AF247	412mm	203mm	15.5mm	212mm		Hino Commercial
Z-AF248	412mm	216mm	15.5mm	211mm		Denning Hino Commercial
Z-AF248HD.35	412mm	216mm	15.5mm	211mm	.35	Hino FS1K
Z-AF249	406mm	127mm	15.5mm	212mm		Hino Commercial
Z-AF253	400mm	115mm	11.5mm	406mm		Isuzu Commercial
Z-AF259	320mm	100mm	8.7mm	327mm		Hino Commercial
Z-AF260	320mm	115mm	8.7mm	328mm		Hino Commercial
Z-AF262	393.7mm	90mm	13mm	380mm		Mitsubishi Commercial
Z-AF264	320mm	75mm	8mm	307mm		Isuzu Commercial
Z-AF267	300mm	75mm	7.5mm	294mm		Isuzu Commercial
Z-AF269	320mm	75mm	8.5mm	307mm		Ford Commercial
Z-AF274	410mm	177.5mm	14mm	210mm		Isuzu Commercial
Z-AF276	320mm	110mm	11mm	332mm		Isuzu Commercial
Z-AF277	320mm	120mm	12mm	332mm		Isuzu Commercial
Z-AF282	320mm	75mm	9.5mm	348mm		Mitsubishi Daihatsu Commercial
Z-AF283	410mm	140mm	16mm	207mm		Mitsubishi Isuzu Commercial
Z-AF284	410mm	200mm	16mm	207mm		Nissan/Mitsubishi Commercial
Z-AF285	400mm	102mm	15mm	214mm		Hino Commercial
Z-AF286	400mm	130mm	15mm	200mm		Hino Commercial
Z-AF287	320mm	100mm	11mm	322mm		Hino Commercial
Z-AF288	320mm	115mm	11mm	311mm		Hino Commercial
Z-AF289	400mm	120mm	15.4mm	213mm		Hino Bus International
						Mitsubishi Nissan Commercial
Z-AF290	400mm	155mm	15.4mm	200mm		Hino Bus, International
						Mitsubishi Nissan Commercial
Z-AF292	410mm	180mm	15.5mm	208mm		Isuzu Commercial
Z-AF295	370mm	100mm	12.7mm	387mm		Mitsubishi Nissan Commercial
Z-AF296	410mm	177.8mm	14mm	210mm		Isuzu Commercial
Z-AF297	410mm	140mm	14mm	119mm		Isuzu Commercial
Z-AF305	410mm	140mm	15.5mm	210mm		Isuzu Commercial
Z-AF311	410mm	115mm	13mm	410mm		Isuzu Commercial
Z-AF316	320mm	110mm	12mm	153mm		Mitsubishi International Nissan
Z-AF317	320mm	130mm	12mm	153mm		Mitsubishi International
Z-AF319	410mm	150mm	15mm	212mm		Nissan Commercial
Z-AF320	410mm	220mm	15mm	204mm		Nissan Commercial
Z-AF321	320mm	110mm	13mm	325mm		Hino Commercial
Z-AF324	320mm	125mm	13mm	325mm		Hino Commercial
Z-AF325	320mm	135mm	12mm	156mm		International Nissan Commercial
Z-AF326	320mm	120mm	12mm	153mm		Mitsubishi Commercial
Z-AF327	320mm	140mm	12mm	153mm		Mitsubishi Commercial
Z-AF329	410mm	219.5mm	16mm	208mm		Mitsubishi Commercial
Z-AF331	410mm	150mm	16mm	208mm		Mitsubishi Commercial

Brake Lining Drillings (All measurements in millimetres)

Brake Lining Sets

PART No.	DRUM DIA	WIDTH	THICKNESS	LENGTH	COF	MAKE OF VEHICLE
Z-AF334	406mm	151.5mm	210mm	210mm		Hino Commercial
Z-AF334HD.35	406mm	151.5mm	15.5mm	210mm	.35	Hino FS1K
Z-AF335	410mm	219mm	15.7mm	204mm		Nissan Commercial
Z-AF336	410mm	150mm	16mm	206mm		Nissan Commercial
Z-AF337	320mm	90mm	8mm	308mm		Ford, Mazda, Hino
Z-AF338	320mm	144.5mm	158mm	158mm		Hino Commercial
Z-AF341	320mm	95.2mm	155mm	155mm		Dodge, Mitsubishi Nissan Commercial
Z-AF342	320mm	114.6mm	155mm	155mm		Dodge, Mitsubishi Nissan Commercial
Z-AF377	393.7mm	101.6mm	424mm	424mm		Nissan Commercial

Brake Lining Drillings (All measurements in millimetres)

Brake Lining Sets

PART No.	DRUM DIA	WIDTH	THICKNESS	LENGTH	COF	MAKE OF VEHICLE
Z-BC/37/1	420mm	200mm	18mm T	222mm	.38	BPW Trailer Axle
Z-BC39/1	400mm	119mm	9.5mm	200mm		BPW Trailer Axle
Z-BT008						FBW
Z-CS/63/1					.38	
Z-CS64/1						
Z-CS67/2						ERF Import
Z-GG/140/1	393.7mm	152.4mm	12.7mm	343mm		Commer, Ford (English) Leyland Commercial
Z-GG142/1	393.7mm	203.2mm	12.7mm	386mm		AEC, Bedford Buses, Bedford, Leyland Commercial
Z-GG144/1	330.2mm	101.6mm	9.5mm	316mm		Ford (English) Leyland, Commercial
Z-GG83/1	393.7mm	152.4mm	12.7mm	386mm		Bedford Buses, Ford (Cargo) Leyland, Commercial
Z-GG92/1	393.7mm	177.8mm	12.7mm	386mm		Bedford Buses, Bedford, Commer, Ford (Cargo) Leyland (BLMC) Commercial
Z-LE01	393.7mm	203.2mm	18.5mm	346mm		Leyland Bus
Z-LE02	393.7mm	203.2mm	18.5mm	346mm		Leyland Bus
Z-LE60/1/2	393.7mm	203.2mm	18.5mm	346mm		Leyland Commercial
Z-LE69/1	393.7mm	152.4mm	19.1mm	346mm		Leyland Tiger
Z-ML/28/1						Mitsubishi Commercial
Z-MP31/1	410mm	160mm	17mm T	190mm		MAN Commercial
Z-MP32/1	410mm	180mm	17mm T	192mm		MAN Mercedes Benz Commercial
Z-MP36/1	410mm	220mm	17mm T	192mm		MAN Commercial
Z-NN40/1	400mm	130mm	15mm	198mm		Nissan Commercial
Z-NN40/1	410mm	180mm	18mm	213mm		Nissan Commercial
Z-NN41/1	410mm	180mm	18mm	213mm		Nissan Commercial
Z-RW9/13/2	311.2mm	190.5mm	16.6mmT	174mm		Trailer Axles
Z-RW9/13/2	311.2mm	190.5mm	15.7mmT	136mm		Trailer Axles
Z-RW29/32/ 33/15						ERF/Rockwell Wedge Brake Front & Rear
Z-SV26/1	412mm	127.0mm	19.1mm	213mm		Scania Commercial

Brake Lining Drillings (All measurements in millimetres)

Brake Lining Sets

BLOCK No.	MATERIAL	COF	TRUCK STOPS PART NO.
1308	NANMRSF Metrotrans	.34	Z-1308ST.34
4311	BMGB	.41	Z-4311JHD.41
4375	HD1L	.37	Z-M4375HD
4515	9ML/HD1L	.37	202SNH204
4515	NAO Protrans	.38	Z-4515EHD.38
4515	BMBC	.39	Z-4515EHD.39
4515	BMGD	.34	Z-4515EHD.34
4515	BMBC	.39	Z-4515EST.39
4515	NAO Econotrans	.41	Z-4515EST.41
4515	NAO Protrans	.38	Z-4515EST.38
4524	9ML/HD1L	.37	202SNH196
4524	MB21	.34	202SNH207
4524	NAO Protrans	.38	Z-4524BST.38
4591	NAO Protrans	.38	Z-4591ST.38
4591	NA100	.38	Z-M4591DNA100
4630	SD1	N/A	Z-M4630D
4649	BMGA	.38	Z-M4649D.38
4649	NAO Econotrans	.41	Z-4649HD.41
4656	TG2	N/A	Z-M4656D
4657	TG2	N/A	Z-M4657D
4662	TG2	N/A	Z-M4662D
4664	TG2	N/A	Z-M4664D
4692	NANMRSF Metrotrans	.34	Z-4692HD.34
4692	NAO Econotrans	.38	Z-4692HD.38
4707	NAO Protrans	.37	Z-4707HD.37
4707	NAO Econotrans	.38	Z-4707HD.38
4709	NANMRSF Metrotrans	.34	Z-4709HD.34
4709	NAO Econotrans	.38	Z-4709HD.38

Brake Lining Sets

PART No.	DRUM DIA	WIDTH	THICKNESS	LENGTH	COF	MAKE OF VEHICLE
Z-SV40/1						Scania Commercial
Z-SV41/1	412mm	203mm	19mm	259mm		Scania Commercial
Z-VL86/1	410mm	150mm	18.7mm	192mm		Volvo Commercial
Z-VL88/1	410mm	200mm	18.7mm	192mm	.39	Volvo Commercial
Z-VL88/1HD	410mm	200mm	18.7mm	192mm	.38	Volvo Commercial
Z-YK/12/1	335mm	210mm	15mm	170mm		Trailer Axles
Z-YK6/7/3						Trailer Axles York

Brake Disc Pads for truck and trailer units

PART No.	WIDTH	THICKNESS	LENGTH	MAKE OF VEHICLE
Z-EDB1328	108mm	30mm	248mm	BPW - SAF 22.5 Knorr
Z-EDB1329	92.5mm	30mm	211mm	BPW - SAF 19.5 Knorr
Z-EFC113	93mm	30mm	210mm	BPW - SAF 19.5 Wabco
Z-EFC114	107mm	30mm	247mm	BPW - SAF 22.5 Wabco
Z-EFC109	100mm	27mm	205.5mm	Mack CH Valueliner Meritor DX19.5
Z-A13222A2367	102.5mm	29mm	235mm	Mack CH Valueliner Meritor 22.5 Rear
Z-EFA207				Brake disc pad clips for EDB1328 and EDB1329 pads
Z-EFA211				Fitting kit for EFC109 pads
Z-EFA216				Pins for EDB1328 and EDB1329 pads
Z-EFA223				Fitting kit for EFC113 pads
Z-EFA224				Fitting kit for EFC114 pads

Brake Disc Rotors

PART No.	HEIGHT	MAX. THICKNESS	DIA. (mm)	SPIGOT DIA. (bore in mm)	MAKE OF VEHICLE
Z-ECD009	150mm	45mm	378mm	222mm	Meritor DX19.5
Z-21224263	150mm	45mm	378mm	225mm	Meritor DX19.5 trailer

Brake Lining Drillings (All measurements in millimetres)

TRAILER BRAKE DRUMS



PART NUMBER	DESCRIPTION	APPLICATIONS
Z-500761	10 Stud STD 335 PCD	York Axle
Z-63637	3 Spoke 7" Spigot	Ingersol Axle
M-TFDR192	10 Stud STD 335 PCD	Ingersol Axle
Z-66884	10 Stud 285 PCD	Ingersol Axle
Z-67518F	5+6 Spoke	Ingersol, York, ROR Axle
Z-68765F	5 Spoke	Fruehauf Axle
Z-7933/J8	8 Stud	Ingersol Axle
Z-80880	10 Stud STD 335 PCD	Ingersol Moss ROR
Z-21018963	10 Stud	ROR Axle Low Loader
Z-21018986	10 Stud STD 335 PCD	ROR Axle
Z-21220183	10 Stud STD 335 PCD	ROR Axle
Z-21209701	10 Stud STD 335 PCD	ROR Axle

BRAKE DRUM SIZE CHART

PART NUMBER	BRAKE FACE DIAMETER	OVERALL DEPTH OF DRUM	WIDTH OF BRAKE SURFACE	BOLT CIRCLE DIA.	PILOT DIA.	BOLTS HOLES AND SIZE
Z-500761	394	236	195	335	282	23.5 (10 Stud)
Z-63637	311	230	198	209	178	19.8 (3 Spoke)
M-TFDR192	420	270	190	335	285	25m (10 Stud)
Z-66884	419	270	194	285	223	24m (10 Stud)
Z-67518F	419	212.8	187.5	279	19.8	19.8 (5&6 Spoke)
Z-68765F	419	222.2	188.9	285	241	20.3 (5 Spoke)
Z-80880	419	242	189.5	285	335	24.3 (10 Stud)
Z-21018963	310	266	200	225	282	25m (10 Stud)
Z-21018986	418	256	200	335	282	25m (10 Stud)
Z-21220183	420	240	185	335	283	25m (10 Stud)
Z-21209701	348	260	214	225	182	25m (10 Stud)

SPRING BRAKE CHAMBER

Z-2024GC
Z-2424GC
Z-2430GC
Z-3030GC

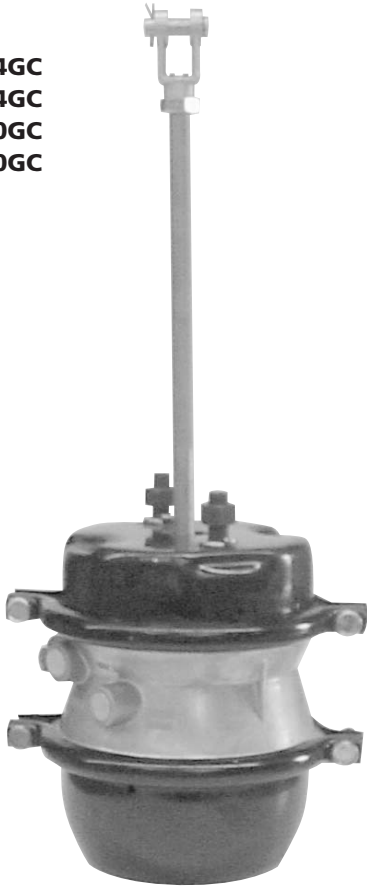

PUSH ROD BOOT

Z-E2764

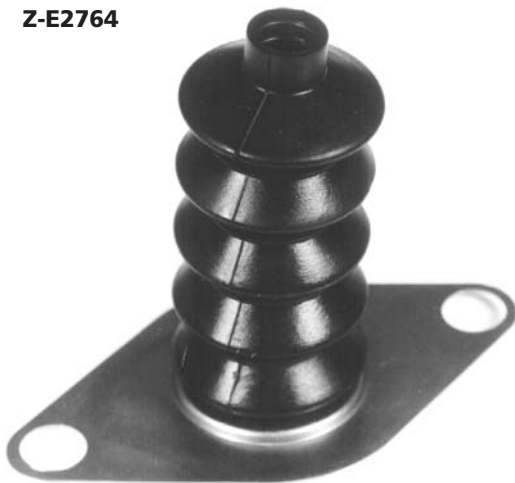

SERVICE CHAMBER

Z-20SC
Z-24SC
Z-30SC

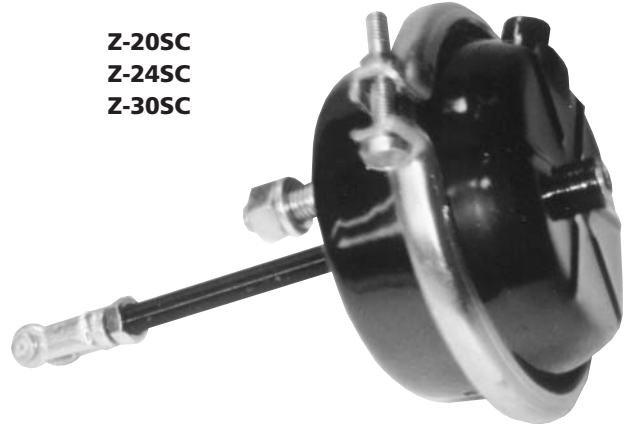

BRAKE CHAMBER DIAPHRAGM

470105LP - TYPE 20
Z-1127M009 - TYPE 24
Longstroke (Deep)
470143LP - TYPE 30



SLACK ADJUSTERS

Part No.
Z-25QD344P2

1 1/2" 28 Spline

5" & 6" length

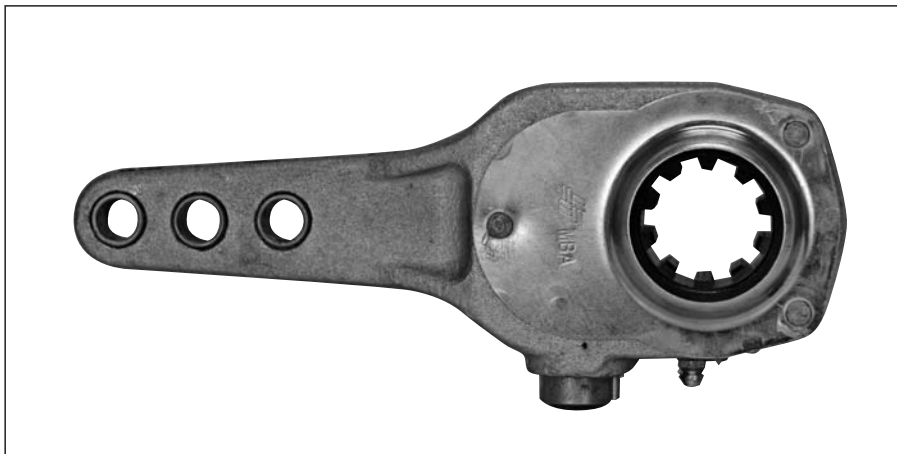
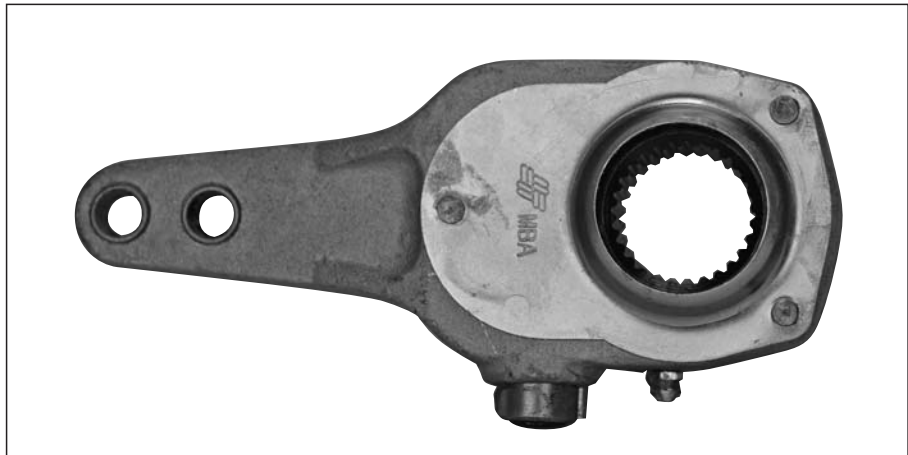

Part No.
Z-25QD243P5

1 1/2" 10 Spline

5", 6" & 7" length

Part No.
Z-E2459BK

1 1/2" 28 Spline

5 1/2" & 6 1/2" length

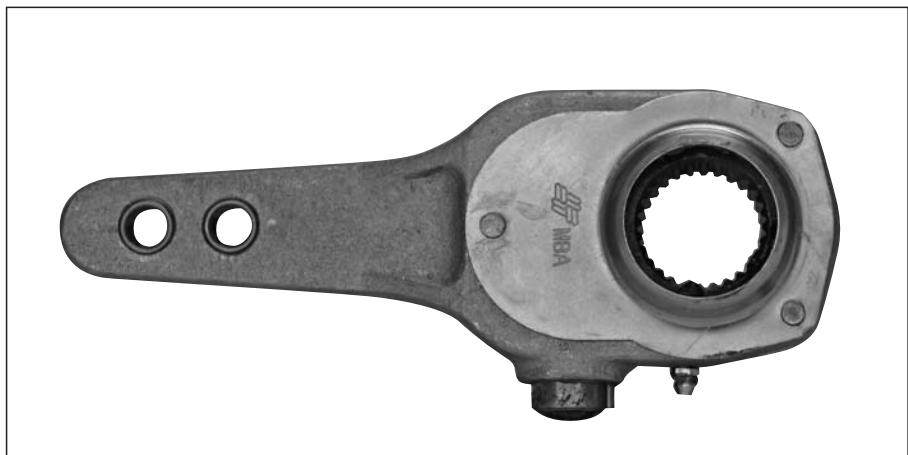

TRACTOR PROTECTION VALVE



Part No. Z-7700

QUICK RELEASE VALVES



Part No. Z-2000B
Cracking Pressure (PSI) 4-5

Part No. Z-2000C
Cracking Pressure (PSI) 8-10

Part No. 0745-800063
Cracking Pressure (PSI) 0-1

SPRING BRAKE EXHAUST VALVES



Part No.	Inlet Port	Outlet Port
Z-780210	3/8 P.T.	3/8 P.T.

SERVICE RELAY VALVES 4-PORT DELIVERY



Part No.	Crack Pressure (PSI)	Ratio Feature
Z-110139	4.5	Yes



Part No.	Crack Pressure (PSI)	Ratio Feature
Z-110450	4.5	No

CHECK VALVES One-Way Check



Part No. Z-2200/8 1/2"
Part No. Z-2200/4 1/4"

CHECK VALVES Two-Way Check



Part No. Z-320100



Part No. Z-5200

SPRING BRAKE CONTROL VALVES



Part No. Z-110903
Protected Reservoir System

PRESSURE PROTECTION VALVE



Part No. Z-1300/80
Adjustable

LEVER CONTROL VALVE



Part No. Z-216050

SERVICE RELAY VALVES 4-PORT DELIVERY



Part No. Z-110380 LOV-4
Crack Pressure (PSI) 1.5



Part No. Z-110415
Crack Pressure (PSI) 4.0

- Nipple mounted 110380 and 110415 are used primarily for tandem axle trailer service brakes with 4 brake chambers.

SERVICE RELAY VALVES 2-PORT DELIVERY



Part No. Z-110360 LOV-2
Crack Pressure (PSI) 1.5



Part No. Z-110410
Crack Pressure (PSI) 4.0

- Nipple mounted 110360 and 110410 are used primarily for single axle trailer service brakes or axle by axle trailer brake designs.

LINE FILTER



Part No. Z-2550

- Commonly used in trailer supply line ahead of spring brake control valve or relay emergency valve. Reduces supply line contamination to extend valve life.

NOTE: Sealco does not recommend the use of line filter in the trailer control line.

SPRINGS TO SUIT RELAY VALVES (LOV STYLE)

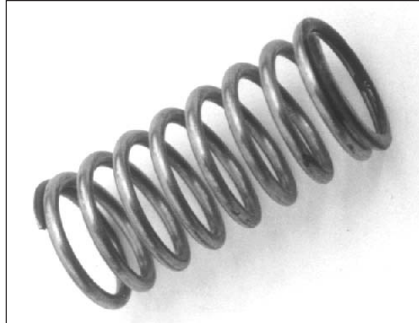

Part No.	Paint Colour	Crack Pressure (PSI)
Z-4048	White	5.5PSI - 37.9Kpa
Z-4040	Gold	4.5PSI - 31.0Kpa
Z-4049	Blue	2.5PSI - 17.2Kpa
Z-4033	Silver	1.5PSI - 10.3Kpa

HAND CONTROL VALVE WITH AUTOMATIC SHUT-OFF



Part No.	Shut-Off (P.S.I.)
Z-99600B	30±5

HAND CONTROL VALVE PUSH-PULL



2-HOLE MOUNTING

Part No.	Comments
Z-17600B	Dolly and Trailer Park Brake Release



2-HOLE MOUNTING

Part No.	Comments
Z-17600	Cab Control

CHARGING RELAY EMERGENCY VALVES



Part No. Z-110470
Cracking Pressure 4.5
Ratio Feature Yes

Bendix®

TRAILER VALVES



R12 Relay Valve

Z-0102277 - 4lb crack
Z-104561 - 5.5lb crack



R12P Pilot Relay Valve

Z-109001



SR2 Spring Brake Valve

Z-106835

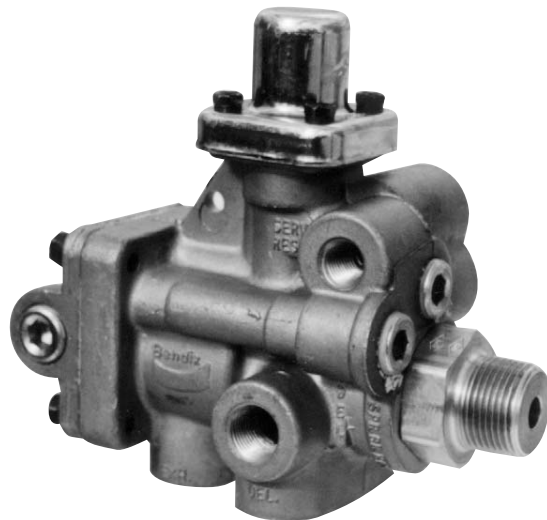

SR5 Spring Brake Valve

Z-109539

TRAILER RATIO RELAY VALVE

Z-971/002/150/0

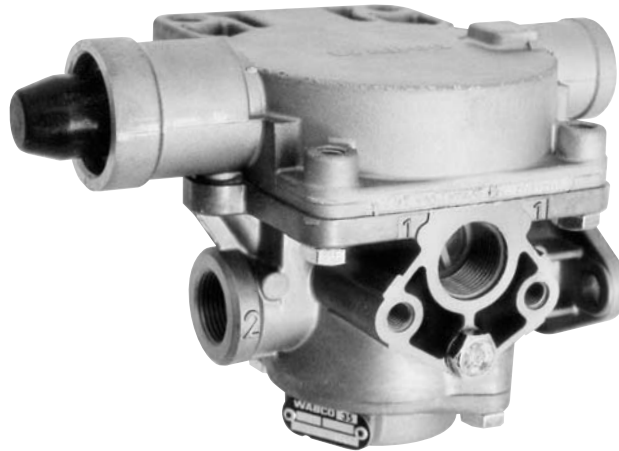

ELECTRIC OVER AIR SOLENOID



TECHNICAL DATA

Part number	Z-472/090/101/0	Z-472/090/202/0
Operating pressure	max. 12 bar	max. 10 bar
Permissible medium	Air	
Operating temperature range	-40 Deg C to 80 Deg C	
Nominal voltage	12V DC	24V DC
Nominal current	670mA	340mA
Weight	0.7Kg	

Purpose: The solenoid valve is mainly used to Actuate pneumatic components in Commercial vehicles and buses.